



PANELBOARD SUPERIOR



TABLE OF CONTENTS

■ REQUIRED TOOLS	03
■ COMPONENT BAGS	04
■ ENCLOSURE SIZING	05
■ WALL MOUNTING	07
■ GLAND PLATES	09
■ SCHNEIDER MCCB/MCB	11
■ NHP / ABB MCCB/MCB	13
■ DOOR REVERSAL	15
■ ESCUTCHEON HINGING	17
■ ENCLOSURE EARTHING	19
■ BOTTOM FED CHASSIS	20
■ EXTENSION BOX	21
■ PANELBOARD ACCESSORIES	23
■ DATA SHEET	24

THE PRODUCT

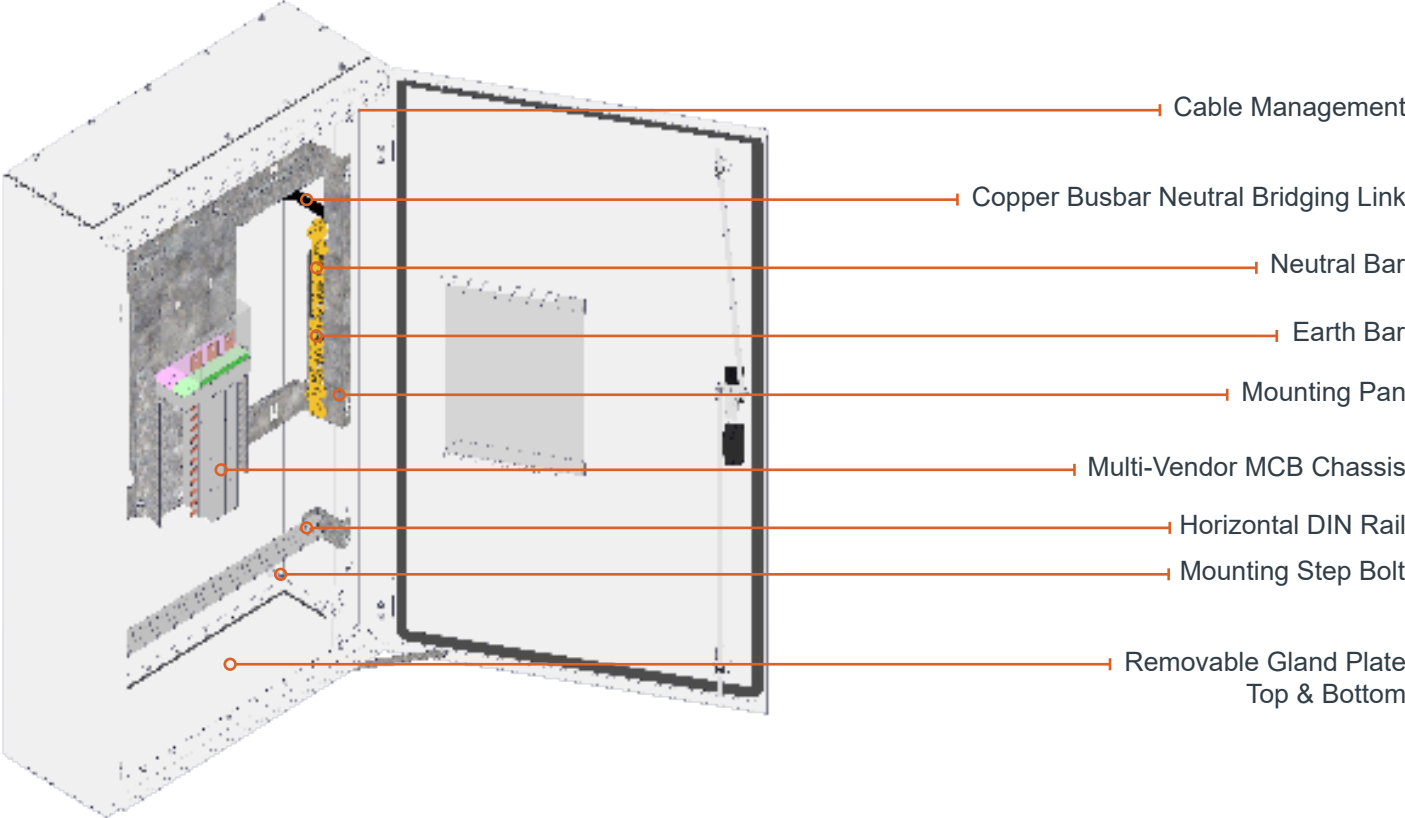
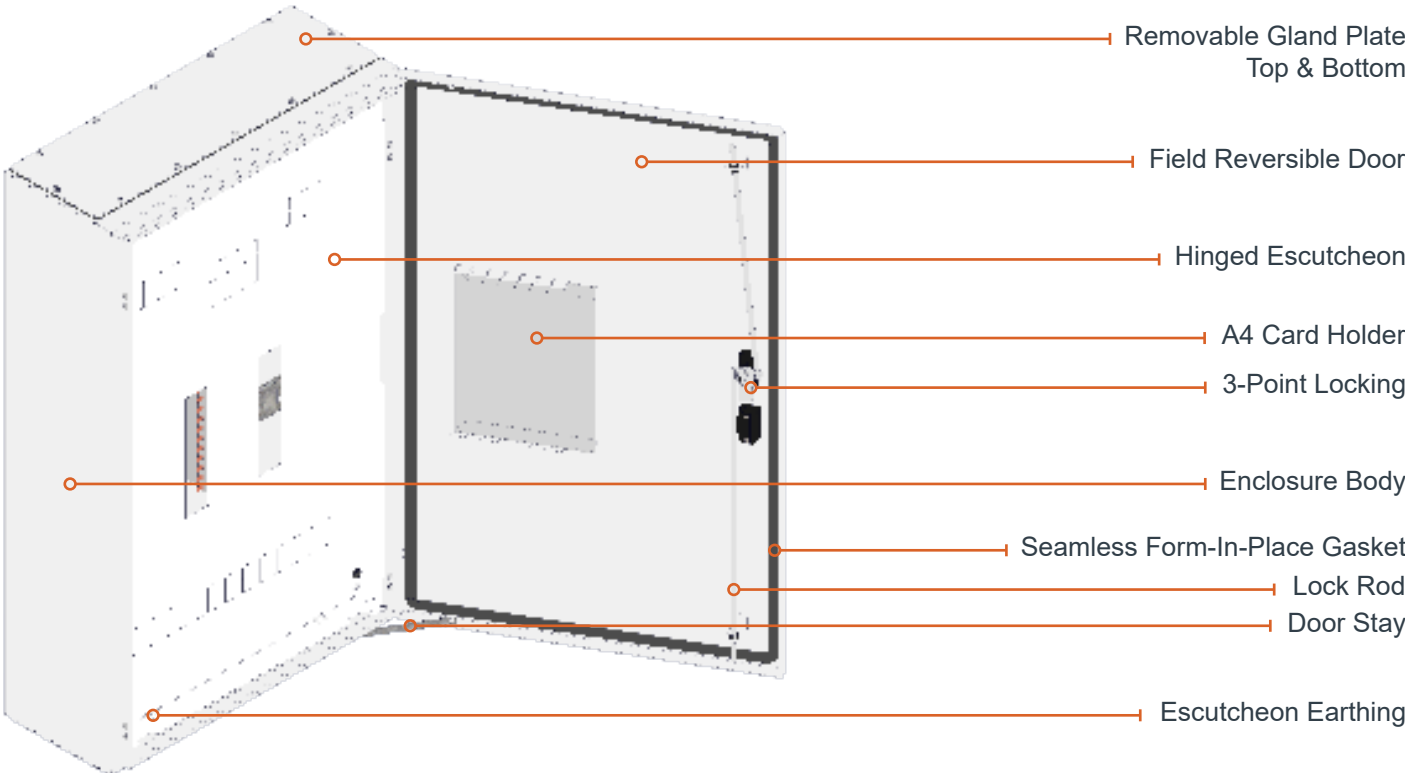

REQUIRED TOOLS

A



PHILLIPS HEAD
SCREWDRIVER

B



FLAT HEAD
SCREWDRIVER

C



RATCHET
SPANNER

D

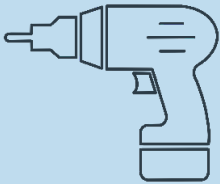

POWER
DRILL

E

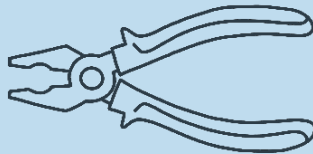

PLIERS

F

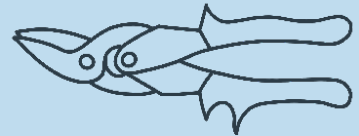

TIN
SNIPS

G

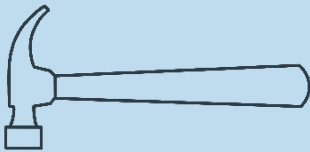

HAMMER

H

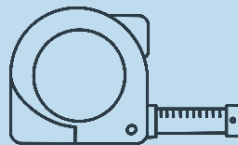

MEASURING
TAPE

I

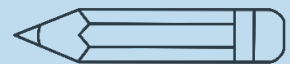

PENCIL /
PEN

COMPONENT BAGS

AA KCA10499

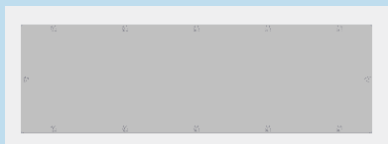

GLAND PLATE (QTY. 2)

- 1 x gland plate
- 1 x gasket
- 12 x M5 hex head screws
- 14 x rubber grommets

BB KCA10530

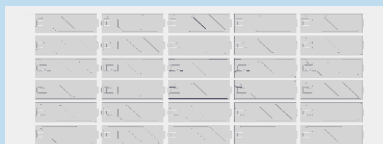

POLE FILLERS (QTY. 1)

- 5 x 6-piece pole filler set (24 pole)
- 6 x 6-piece pole filler set (36 pole)
- 7 x 6-piece pole filler set (48 pole)
- 8 x 6-piece pole filler set (60 pole)
- 9 x 6-piece pole filler set (72 pole)

CC KCA10500



EARTH LEAD (QTY. 1)

- 1 x earth lead
- 1 x M5 hex head screws

DD KCA10529



WALL MOUNT (QTY. DIFFERS)

- 4-6 x MEB/S bracket
- 4-6 x M8 hex head screws
- 4-6 x M8 shakeproof washer

EE KCA10523



MCCB EXTRAS (SIZES DIFFER)

- 2 x 16mm Schneider DIN rails
- 2 x 19mm NHP DIN rails
- 3 x Schneider copper busbars
- 3 x NHP copper busbars
- 1 x NHP mounting bracket
- 10-17 x M5 hex head screws

ENCLOSURE SIZING

The Superior line provides IP66 enclosures in five different sizes. The sizes of the enclosures vary only in height, with the width and depth staying consistent throughout the range.

The height differences are largely dependent on the poling size of the B&R multi-vendor chassis.

24 POLE

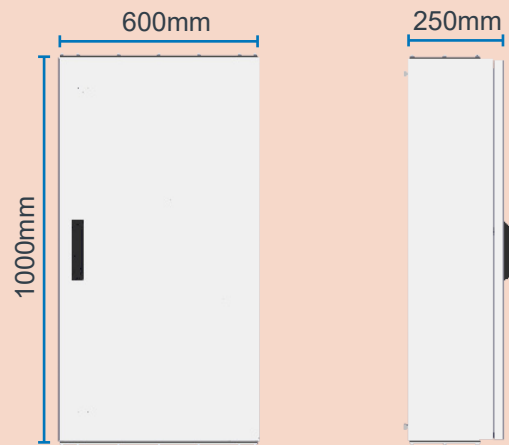
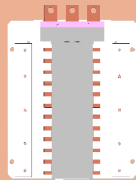

36 POLE

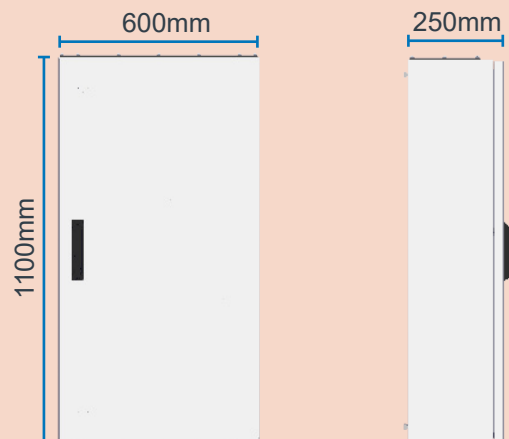
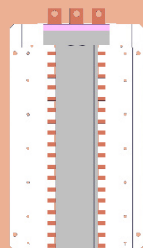

48
POLE

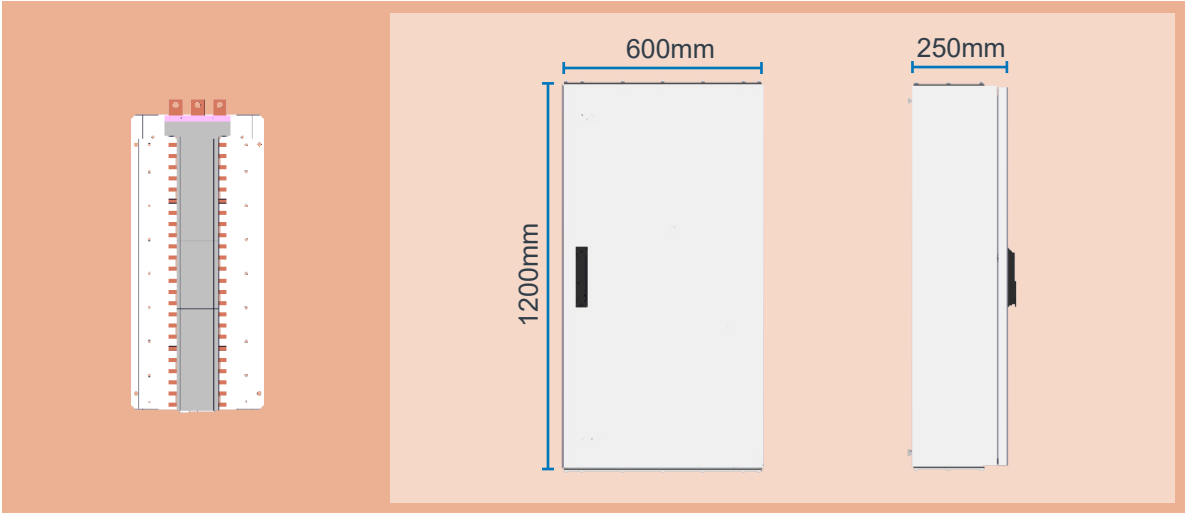

60
POLE

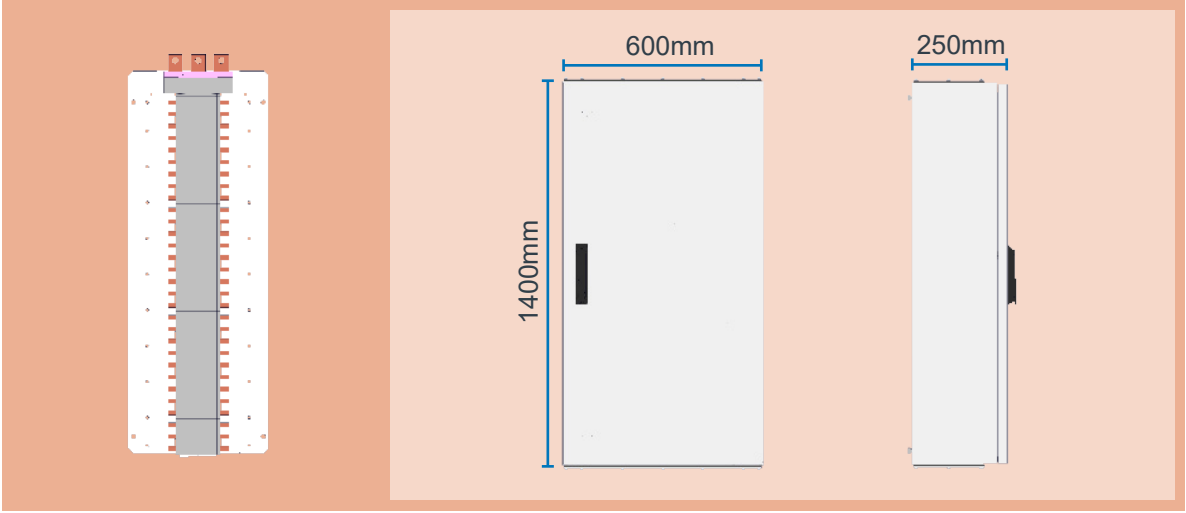

72
POLE

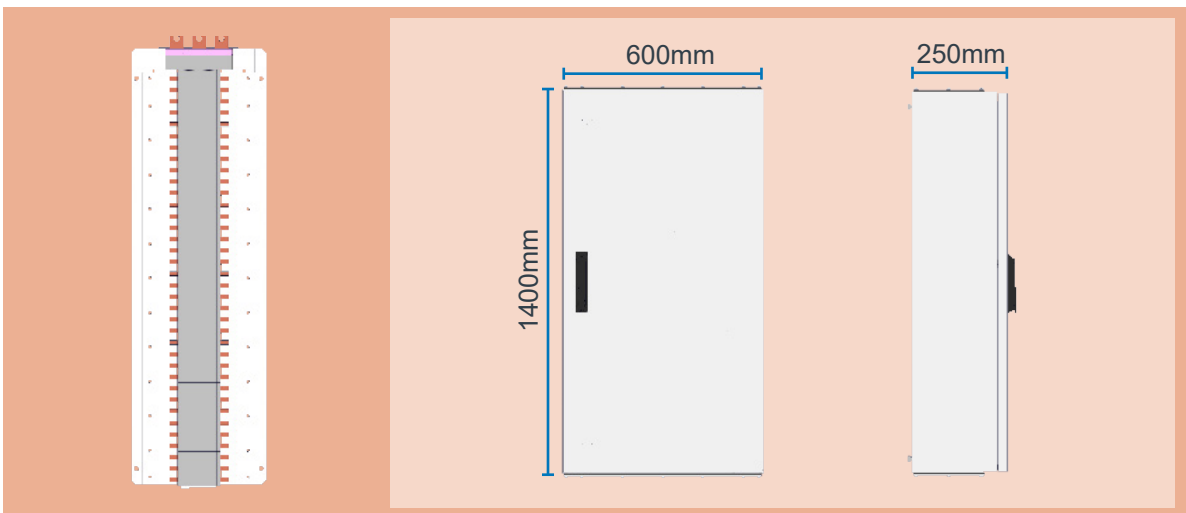

WALL MOUNTING

It is strongly recommended that the panelboard enclosure be wall mounted using the B&R MEB/S wall mounting brackets provided with the purchase of the enclosure. Depending on the enclosure size, either four or six brackets will need to be used to securely anchor the enclosure to the wall.

REQUIRED TOOLS

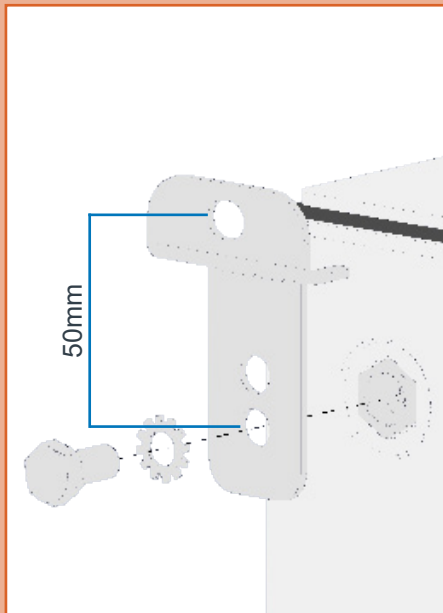
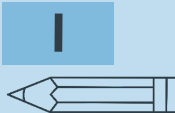
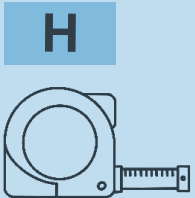
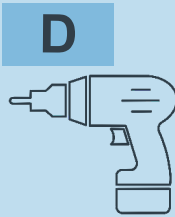

If mounting the enclosure using vertically positioned MEB/S brackets, locate the bracket in its desired position and then fit the bracket to rear of body as indicated. Once secure, the bracket provides a mounting hole above or below the enclosure.

The same process can be used for the central mounting locations on the larger enclosures, but with the brackets positioned horizontally instead.

COMPONENT BAGS

DD



IMPORTANT NOTE



When fastening the wall mounting brackets, they must be attached in the vertical position so as to allow for optimum distribution of weight and anchorage to the wall.

The exception to this rule exists for the central mounting locations of the larger enclosures (60 & 72 pole), where the brackets are required to be attached in a horizontal position.

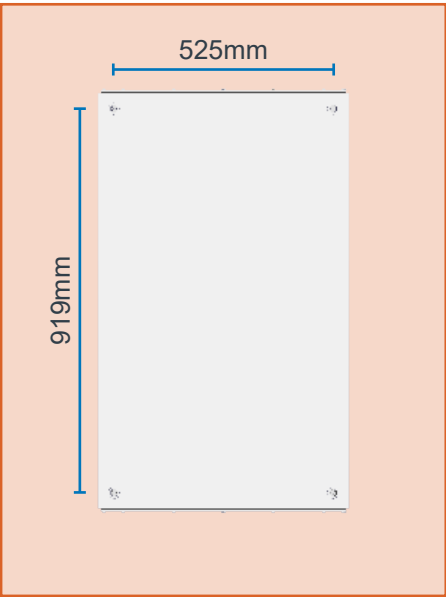

24 POLE

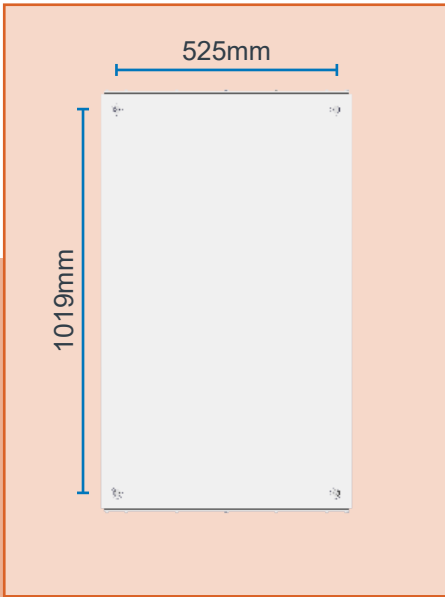

36 POLE

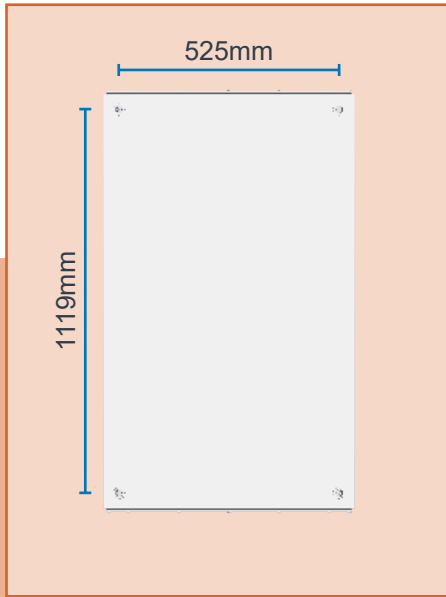

48 POLE

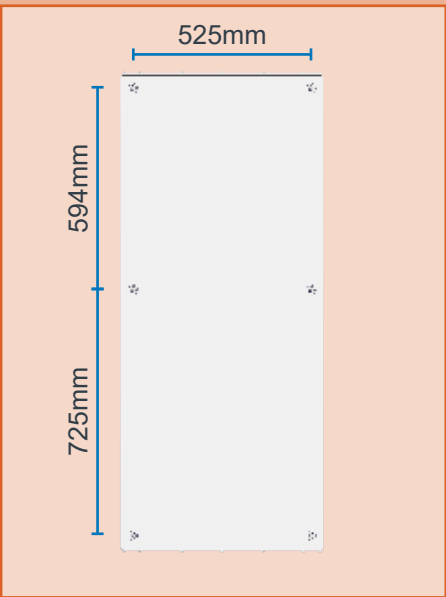

60 POLE

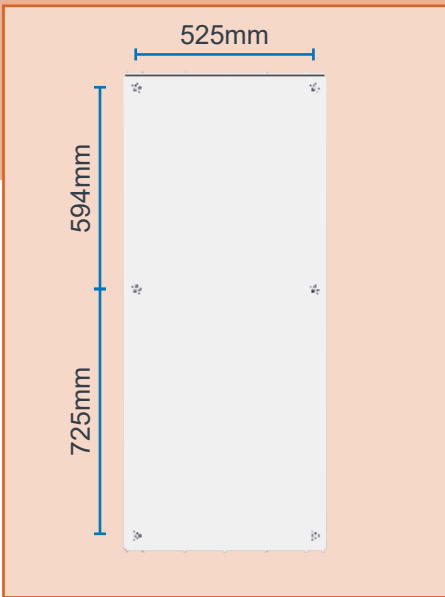

72 POLE

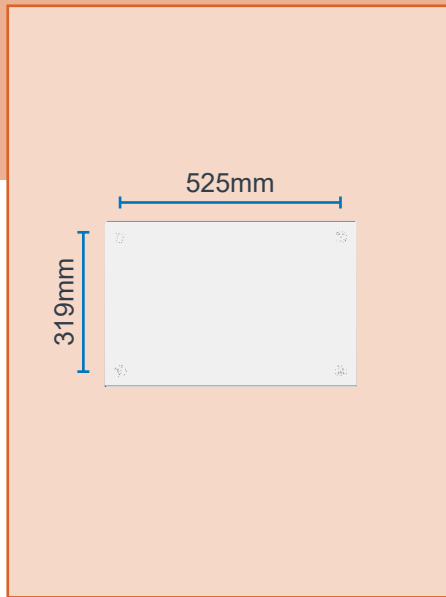

EXTENSION BOX

GLAND PLATES

REQUIRED TOOLS

A

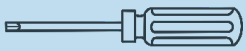

C

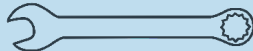

COMPONENT BAGS

AA

x2

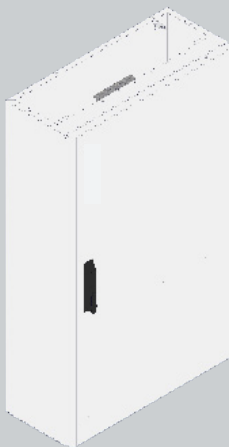

1 Upon receipt of the enclosure, it must be assembled using this guide and the provided component bags to achieve the IP66 rating.

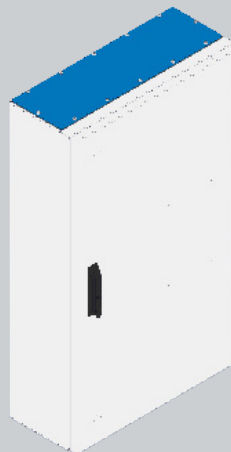

2 Locate the two component bags containing the gland plates. Ensure their contents align with that listed on page 3.



3 Open the first component bag and press each of the rubber grommets into the holes of the gland plate, before placing the plate in its correct position.

BAYING & BOTTOM FED CHASSIS

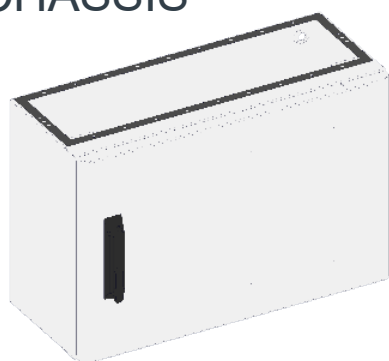

If there are plans to change the enclosure from top to bottom feeding and/or baying of an extension box, then these steps found on pages 19 and 21 respectively, should be completed before attachment of gland plates.

IMPORTANT NOTE



The rubber grommets used in the assembly of the gland plates must be added to the gland plates prior to the attachment of the screws.

These grommets can simply be pressed into the related holes in the gland plates.

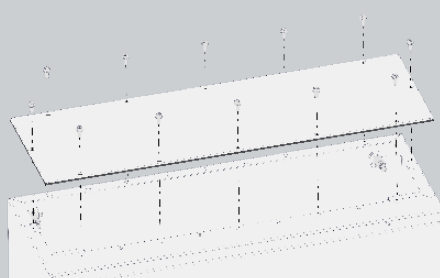
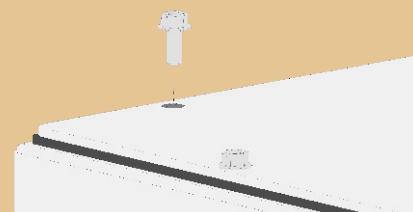

4 The holes of the gland plate will align with the 'burst' extrusions on both the top and bottom of the enclosure.



5 Each screw should be fastened using relevant screwdriver or ratchet spanner.



6 Fasten screws until resistance is met and the head of the screw sits flat against the top of the gland plate.

Repeat this process with the second gland plate.

SCHNEIDER MCCB/MCB

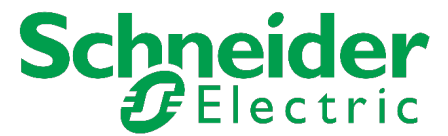

The Panelboard initially offers a multi-switchgear vendor option, but once a vendor is chosen, it is essential to stick to that selection. The enclosure is compatible with Schneider, NHP MOD6, or ABB MCB breakers. For the main switch, either the Schneider NSX or the Terasaki MCCB ranges can be used to serve as a breaker or an isolator in a non-auto MCCB configuration.

REQUIRED TOOLS

A



B

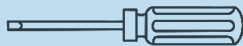

C

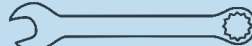

COMPONENT BAGS

EE



DIN RAIL & COPPER BUSBAR

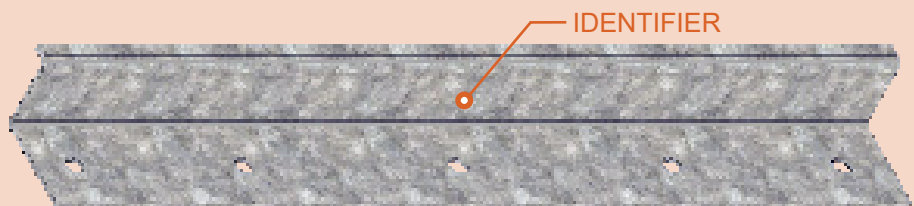
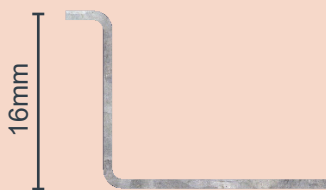

In order to successfully mount the Schneider breakers, the correct vertical DIN rails must be installed. These DIN rails, supplied in the related component bag, are identified by their 16mm depth, or the single identification hole located on the rail, as highlighted in the image above.

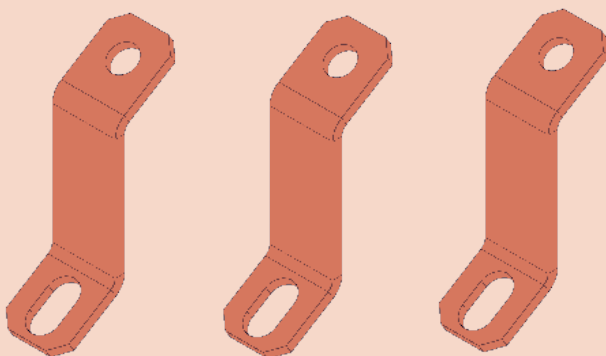

Along with the two vertical DIN rails, the component bag also contains pre-bent copper busbars. The Schneider busbars can be identified through their larger size when placed in comparison with the NHP busbars.

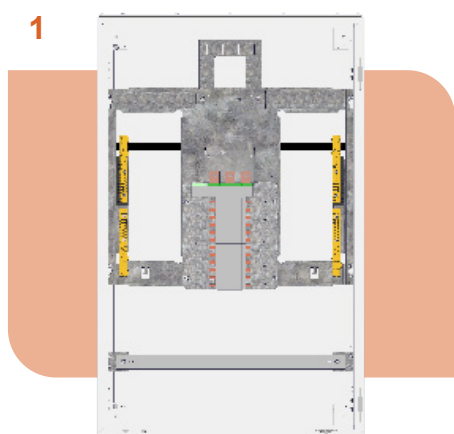

The image above is what the internals of the enclosure look like upon purchase.

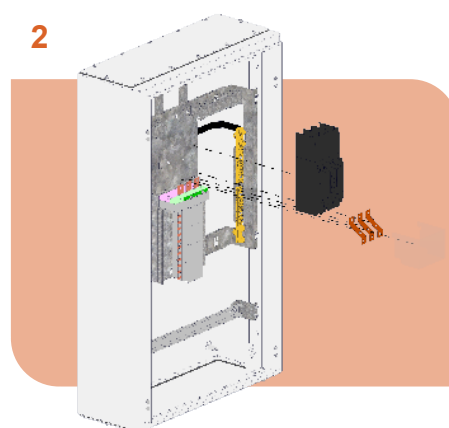

While the MCCB and breakers must be bought separately, the copper busbars and DIN rails are provided in the related component bag (ensure contents align with that listed on page 3).

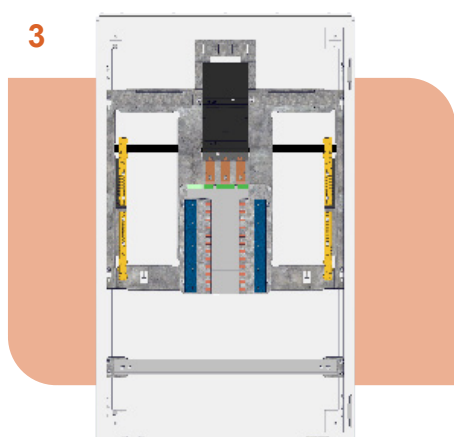

The clear polycarbonate cover located at the top of the chassis should be removed before fixing the MCCB. The two mounting holes on the MCCB must align with the two nutsert fixing points on the mounting pan. The vertical DIN rails should then be fastened on either side of the chassis.

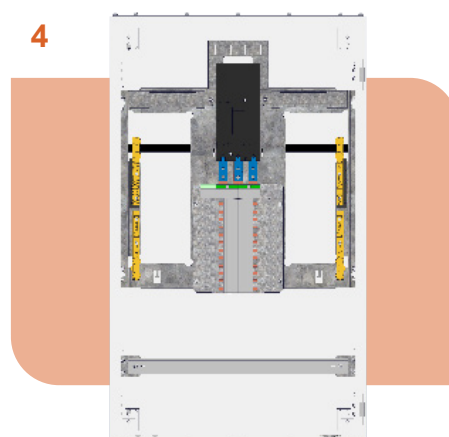

The copper busbars can then be fixed before the polycarbonate cover is reattached.

NHP / ABB MCCB/MCB



The Panelboard initially offers a multi-switchgear vendor option, but once a vendor is chosen, it is essential to stick to that selection. The enclosure is compatible with Schneider, NHP MOD6, or ABB MCB breakers. For the main switch, either the Schneider NSX or the Terasaki MCCB ranges can be used to serve as a breaker or an isolator in a non-auto MCCB configuration.

REQUIRED TOOLS

A



B

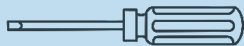

C



COMPONENT BAGS

EE



DIN RAIL & COPPER BUSBAR

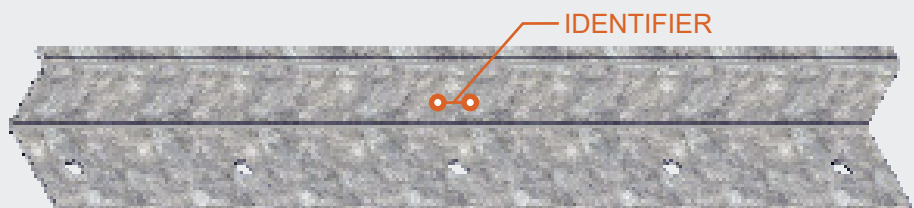
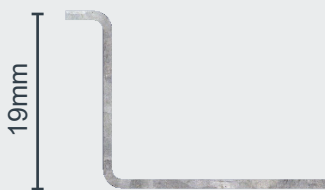

In order to successfully mount the NHP / ABB breakers, the correct vertical DIN rails must be installed. These DIN rails, supplied in the related component bag, are identified by their 19mm depth, or the two identification holes located on the rail, as highlighted in the image above.

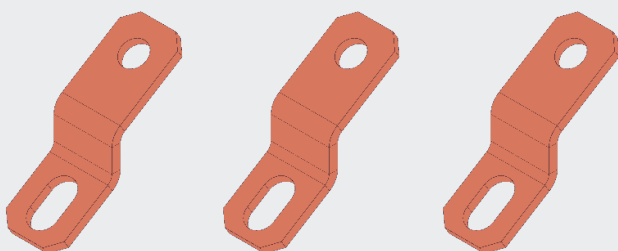

Along with the two vertical DIN rails, the component bag also contains pre-bent copper busbars. The NHP / ABB busbars can be identified through their smaller size when placed in comparison with the Schneider busbars.

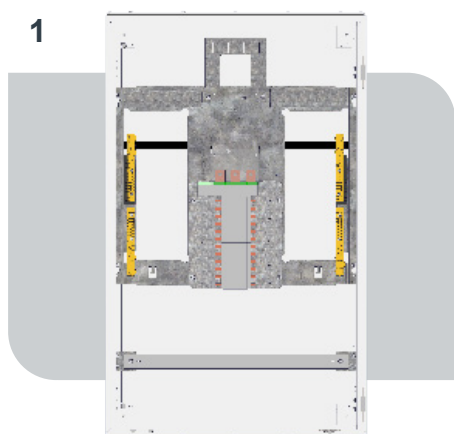

The image above is what the internals of the enclosure look like upon purchase.

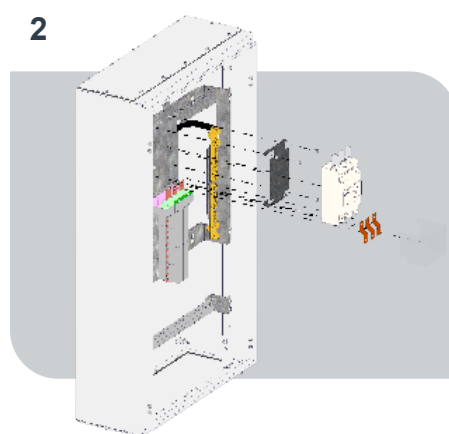

While the MCCB and breakers must be bought separately, the copper busbars and DIN rails are provided in the related component bag (ensure contents align with that listed on page 3).

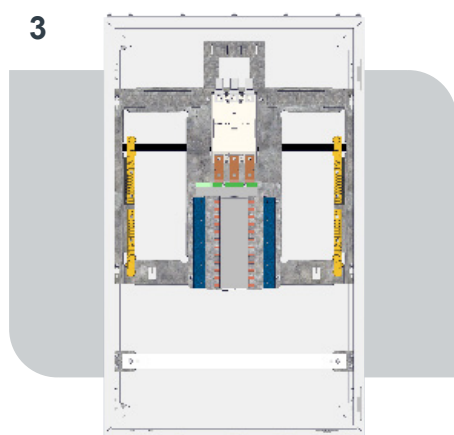

The clear polycarbonate cover at the top of the chassis should be removed before fixing the MCCB. The mounting bracket should align with the four related holes on the mounting pan – fix it using screws provided. Mount the MCCB to this bracket using the two nutsert fastening points and fixings provided. Fasten vertical din rails on either side of the chassis.

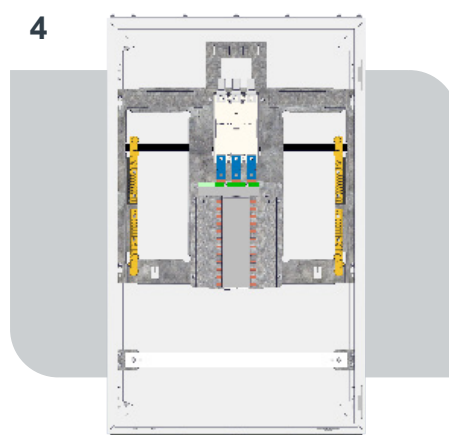

The copper busbars can then be fixed before the polycarbonate cover is reattached.

DOOR REVERSAL

REVERSE HINGING PROCESS

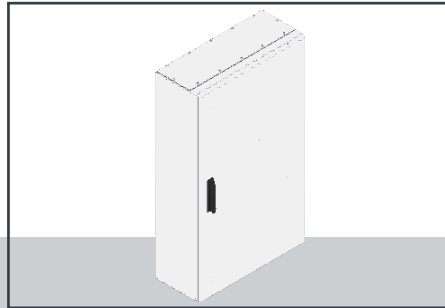

1 The enclosure can be hinged from either the left or the right.

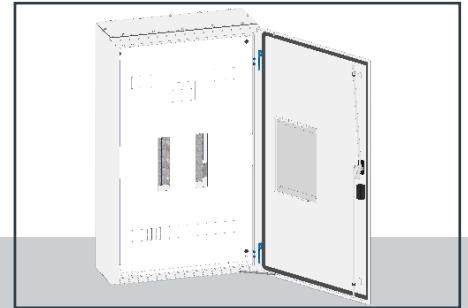

2 To reverse the hinging of the door, it must first be opened and the hinges (either 2 or 3) located.

IMPORTANT NOTE



Due to the pintle method of the door hinging, the body of the Panelboard itself cannot be rotated to alter the door hinging as the door will disengage and fall off.

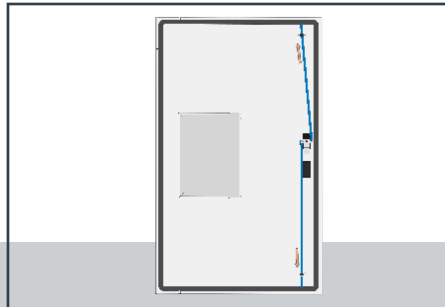

6 Once removed, lift lock rods from locking mechanism, separate from brackets and set aside.

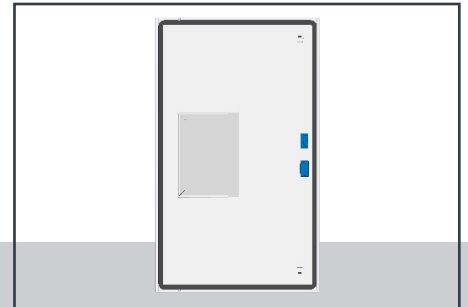

7 Unscrew locking mechanism using a screwdriver and set aside - remembering its orientation.

REQUIRED TOOLS

A



E

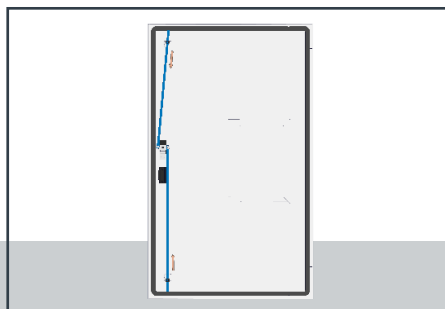
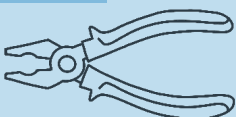

11 Reinsert lock rods through brackets. Ensure shorter is at top of door and angled edge facing inwards.

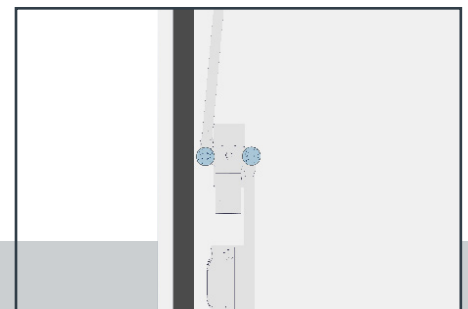

12 Reattach 'c' overtop lock rods (best achieved using pliers).

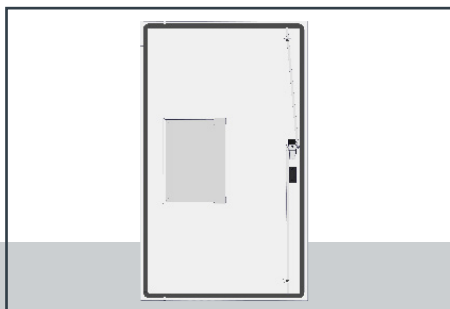

3 Lift door stay off stud located at bottom of door, unscrew from body and set aside.

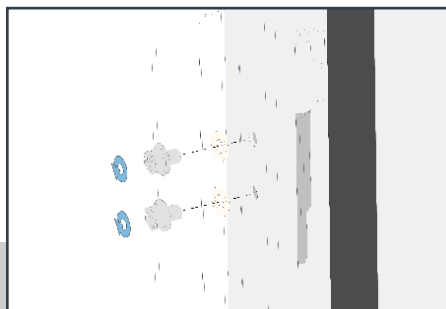

4 Using a screwdriver, unfasten hinge assemblies (2x screws, 2x nylon washers, 1x hinge) - set aside.

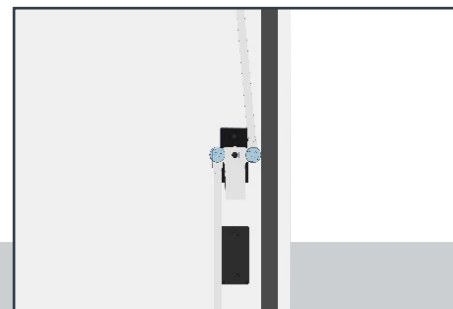

5 Lie door on flat surface, and unfasten 'c' clips that keep lock rods in place (easiest if using pliers).

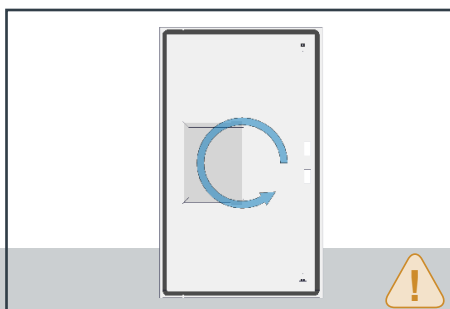

8 Rotate door so that it is sitting in its new hinging orientation.

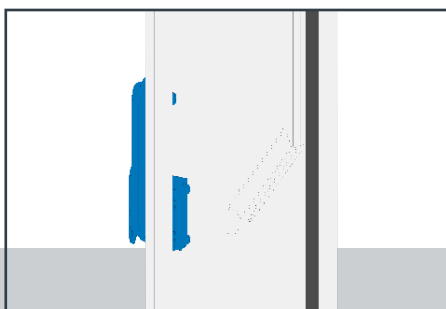

9 Reattach lock mechanism. Ensure the larger box of the mechanism is oriented towards bottom of door.

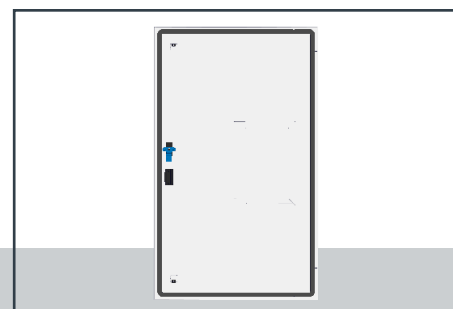

10 Orient locking cam in downward direction to make the reassembly of the lock rods easy.



13 Reattach hinges on the opposite side of enclosure from where they were removed from.

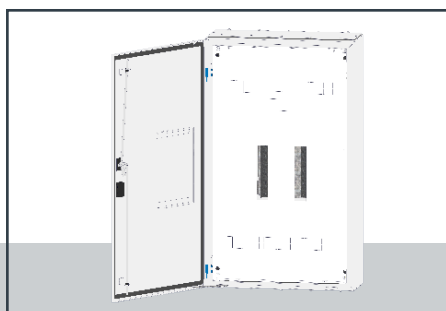

14 Rehang door overtop of hinges.

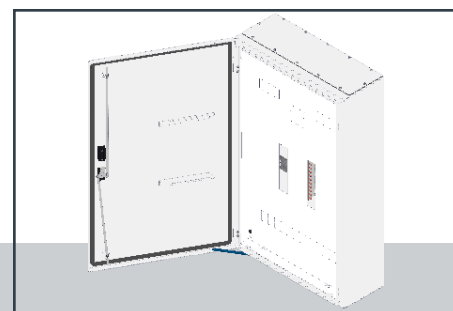

15 Unfasten door stay and refasten on new hinging side (also swapping over rubber hinge plugs).

ESCUTCHEON HINGING

HINGE REVERSAL

The escutcheon can be reverse hinged to suit either left or right opening, as well as rotated to enable both top and bottom-fed chassis.

The following process is a guide for altering the escutcheon to suit a bottom-fed chassis.

IMPORTANT NOTE



If the escutcheon is flipped, new poling stickers of the correct orientation need to be ordered to retain compliance.

REQUIRED TOOLS

A

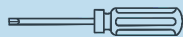

E



F



G



1 The escutcheon will come fastened when first purchased, but can be easily altered.

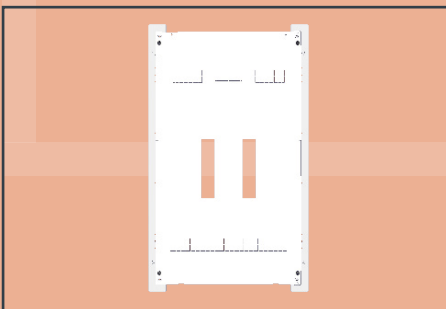

2 Undo screw securing the wide horizontal bracket at top of the escutcheon - set aside bracket.

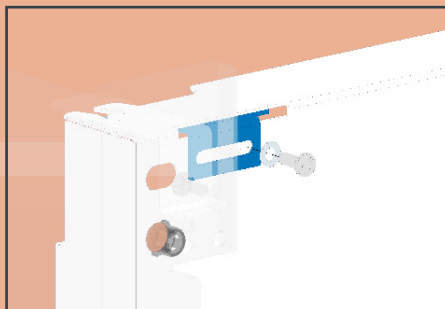

3 Locate the two studded brackets fastened both at the top and the bottom of hinged side of escutcheon.

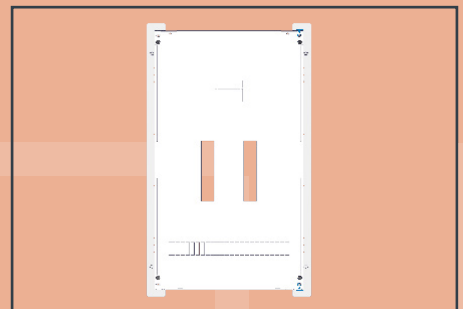

4 Separate escutcheon body from studded brackets. Set aside.

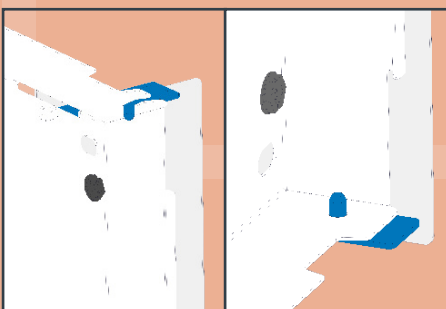

5 Using a screwdriver, unfasten same brackets from vertical body rail - make note of bracket positioning.

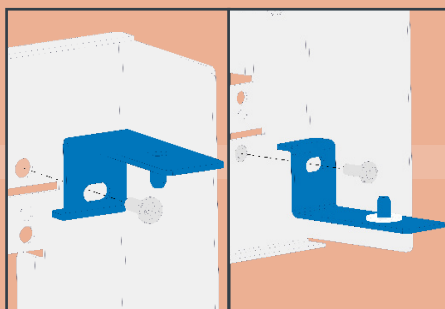

6 Unfasten studs at top and bottom of original non-hinging side using a spanner and swap to opposite rail.

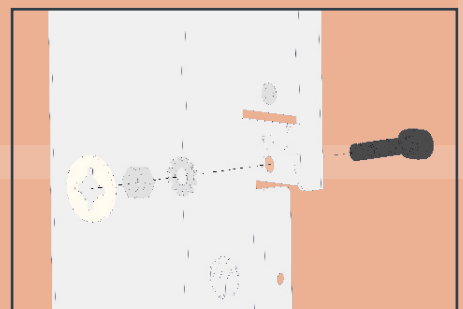

ENCLOSURE EARTHING

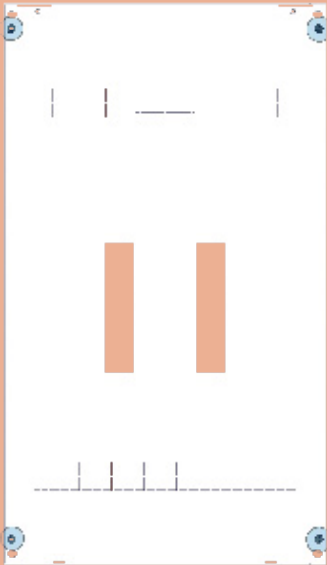

Earthing of the enclosure's escutcheon is created through the securing of the locknuts located on the non-hinging side of the escutcheon. When these nuts are tightened to lock the escutcheon in the closed position, an earthing connection is created.

If further earthing is desired, a component bagscontaining an earth lead is also provided with the enclosure.

ADDITIONAL EARTHING

ESCUTCHEON EARTHING

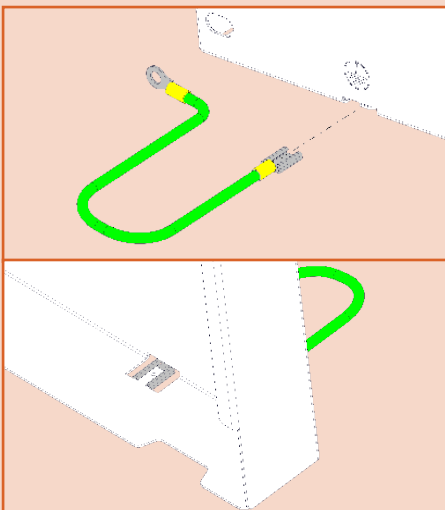

The spade terminal must be fixed to the escutcheon from inside the enclosure. The spade terminal should be applied to the escutcheon tab closest to the hinged side of the escutcheon.

BODY EARTHING

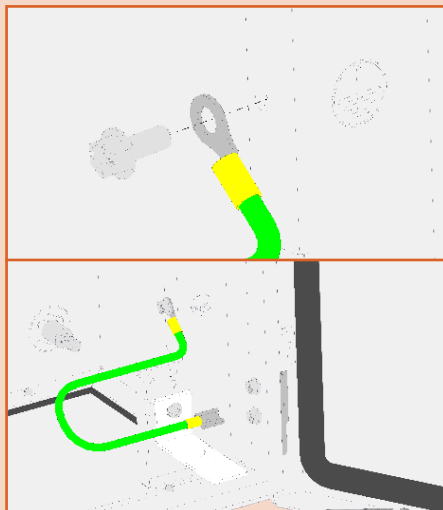

The eye terminal fastens inside the enclosure. The location it is fastened should always be closest to the escutcheon hinging point.

Fasten the terminal using the screw provided.

REQUIRED TOOLS

A



C

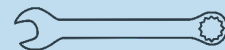

COMPONENT BAGS

CC



BOTTOM FED CHASSIS



The standard enclosure is assembled to suit a top-fed chassis.

For a bottom-fed incomer, the chassis internal assembly of the enclosure needs to be rotated.

REQUIRED TOOLS

A



C

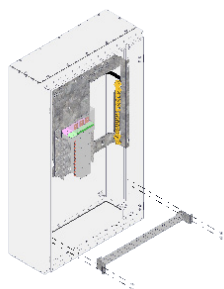

1 Unfasten horizontal DIN rail from enclosure body using a screwdriver and set aside.

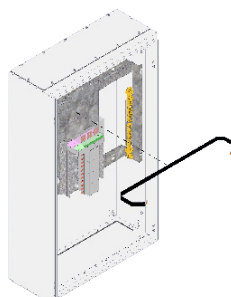

2 Unfasten and set aside the copper neutral bar to allow for easy manipulation of the mounting pan.

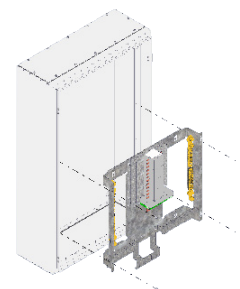

3 Unfasten mounting pan and rotate 180 degrees. Refasten in new orientation, using holes where the DIN rail was originally located.

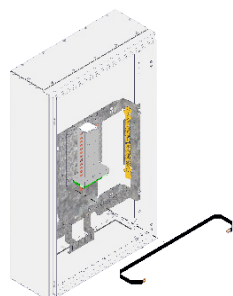

4 Reattach copper neutral bar in its original position on the mounting pan, connecting the neutral poles.

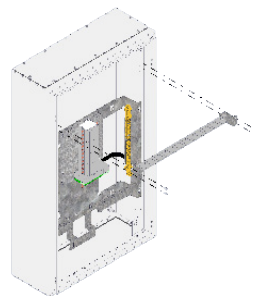

5 Refasten horizontal DIN rail in the enclosure above the mounting pan.

IMPORTANT NOTE



Due to the pintle method of the door hinging, the body of the Panelboard itself cannot be rotated to create a bottom fed enclosure as the door will disengage and fall off.

EXTENSION BOX

The extension box comes with a standard 48 pole DIN configuration, but it has been designed to be multifunctional. This means it can be reconfigured to a single 24 pole DIN rail if more space is required for cabling, or alternatively, utilised in situations where CT fitments are required for power monitoring (through use of the mounting pan).

The processes outlined earlier in the leaflet regarding customisations – e.g. door and escutcheon hinging, wall mounting etc. can also be applied to the extension box to allow it to suit all scenarios.

DIMENSIONS & WALL MOUNTING

OVERALL DIMENSIONS

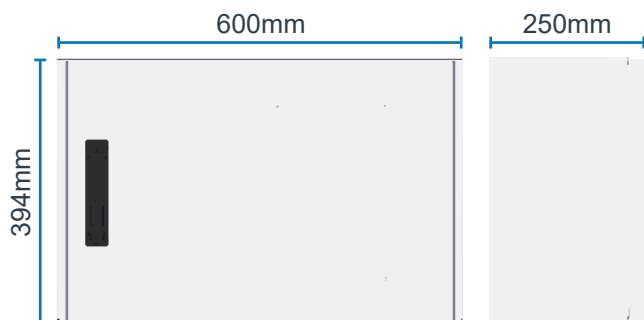

Dimensions allow the extension box to sit flush with the larger enclosures.

WALL MOUNTING DIMENSIONS

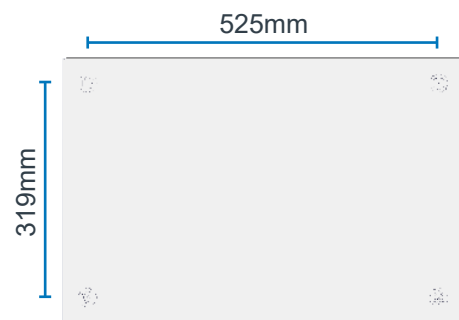

Extra wall mounting brackets are provided with the purchase of the extension box.

IMPORTANT NOTE



The extension box must be bayed to the main enclosure and gland plates attached to ensure the IP66 rating is maintained.

GLAND PLATES

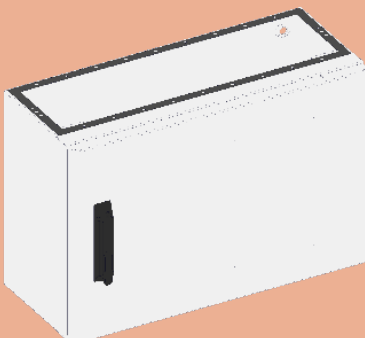

If the extension box is purchased with the initial order of the Panelboard product, then it is highly recommended that the gland plates are not applied until after the main enclosure and extension box have been bayed together.

This will save time and resources as once the rubber grommets utilised in the fastening of the gland plates have been used once, they must be replaced before refastening.

BAYING

IF GLAND PLATES ARE ATTACHED

1 Prior to adding the extension box, unfasten gland plate at bottom of enclosure using screwdriver / ratchet spanner - set aside.

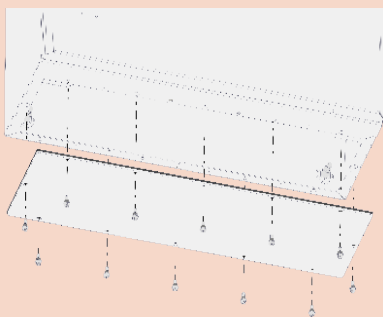

2 Fit gasket on top of extension box before aligning the box at base of the main body and fastening with provided fixings.

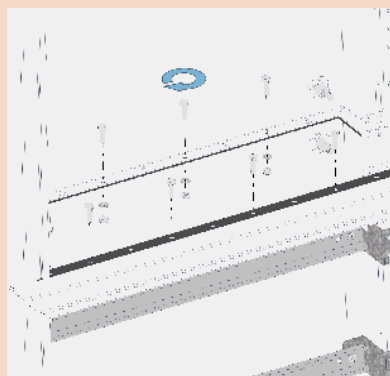

3 Attach gland plate in new location at base of extension box. Ensure new grommets used when refastening gland plate.

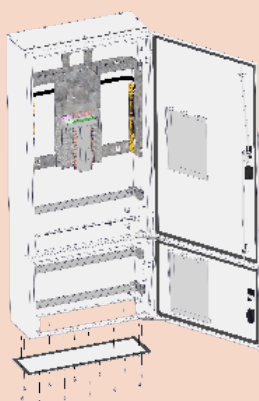

4 The extension box should now be firmly fastened to the main panelboard enclosure and hinged on the same side.

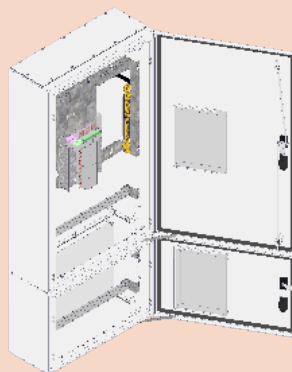

REQUIRED TOOLS

A



C



E

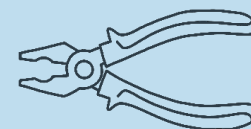

COMPONENT BAGS

FF

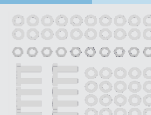

PANELBOARD ACCESSORIES

With the ability to alter the standard Panelboard in order to best suit user environment, further component bags can be purchased.

EXTENSION BOX

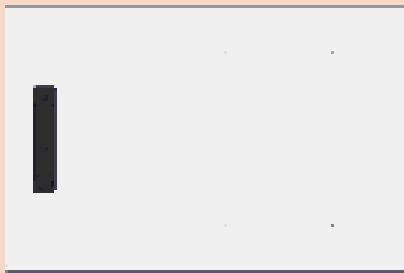

With the purchase of the extension box, additional component bags are automatically included.

FF KCA10502

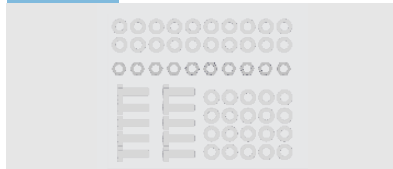

EX. BOX BAYING (QTY. 1)

10 x M6x20mm hex head screws
10 x M6 shakeproof washer
10 x M6 nuts

GG KCA10179

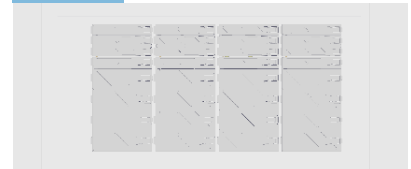

EX. BOX POLE FILLERS (QTY. 1)

7 x 6-piece pole filler set

HH KCA10529



WALL MOUNT (QTY. 1)

4 x MEB/S bracket
4 x M8x16mm hex head screw
4 x M8 shakeproof washer

JJ KCA10500

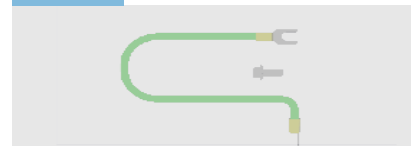

EARTH LEAD (QTY. 1)

1 x earth lead
1 x M5x12mm hex head screw

KK PF6TR/PK



EXTRA POLE FILLERS (QTY. 1)

3 x 6-piece pole filler set

DATA SHEET

PANELBOARD							
OVERVIEW	SERIES NAME	SUPERIOR					
	IP RATING	IP66					
	MCB POLES	24 Pole	36 Pole	48 Pole	60 Pole	72 Pole	Extension Box
ENCLOSURE DETAILS	HEIGHT	1000	1100	1200	1400	1400	394
	WIDTH	600	600	600	600	600	600
	DEPTH	250	250	250	250	250	250
	MATERIAL	Zincanreal (1.6mm)					
		Stainless steel (1.5mm)					
	COLOUR	RAL7035 (light grey)					
		X15 (orange)					
	LOCKING	3-point					
	KEY LOCKABLE	Yes (keyed 92268)					
	REMOVABLE DOOR	Yes					
	REVERSIBLE DOOR HINGE	Yes					
	HIDDEN HINGES	Yes					
	DOOR INDEPENDENT OF ESCUTCHEON	Yes					
	HINGED ESCUTCHEON	Yes					
	REVERSIBLE ESCUTCHEON HINGE	Yes					
	REVERSIBLE ENCLOSURE	No					
	CABLE MANAGEMENT	Yes					
DISTRIBUTION SCHEDULE CARD	Yes						
REMOVABLE GLAND PLATES	Yes (3mm aluminium as standard)						
POLE FILLERS	Yes						
CUSTOMISABILITY	EXTENSION BOX (BAYED)	Option					
	WALL MOUNTING	Option					
	SCHNEIDER MCB	Option					
	NHP/TERASAKI MCB	Option					
	BOTTOM FED	Yes (with rearranged internal chassis)					
ELECTRICAL DETAILS	CHASSIS FAULT RATING	20kA (0.1s)					
	TYPE TESTING	To AS/NZS3439					
	ASTA TEST CERTIFICATE NO.	19301651-003					
	RATED CURRENT (In)	250A					
	RATED VOLTAGE (Un)	415V					
	RATED OPERATIONAL VOLTAGE (Ue)	230/400V					
	RATED INSULATION VOLTAGE (Ui)	440V					
	RATED IMPULSE VOLTAGE (Uimp)	6kV					
	SPARE DIN RAIL POLES	24 poles below mounting pan + 12 poles on left and right of main switch					
	NEUTRAL BARS	Both sides with individual tunnels per pole					
	NEUTRAL BARS BRIDGED FROM LHS TO RHS	Yes					
	NEUTRAL BRIDGE RATING	250A					
	EARTH BARS	Both sides with individual tunnels per pole					
	EARTH AND NEUTRAL BAR TUNNELS	Double screw tunnel					
EARTH AND NEUTRAL BAR CONNECTION	2 x M10 stud points						
EARTH AND NEUTRAL BAR RATING	250A						

B&R ENCLOSURES

Tel: +61 7 3714 1111

Email: enquiries@brenclosures.com.au

Location: 51 Stradbroke St, Heathwood
QLD, 4110