



Installation, operation and maintenance manual

Cooling units for door or wall mounting



CE
UK
CA
EAC



NXT

ATTENTION!

Read carefully and completely before installation. Keep the manual until unit decommissioning.



1. General Information.....	8
1.1 Overview.....	8
1.2 Purpose of the Manual.....	8
1.3 Symbols Contained in this Manual.....	8
1.4 Retention of Documents.....	8
1.5. Updates.....	8
1.6. Technical Features.....	8
1.7. Cooling Unit Application.....	8
1.7.1 Intended Use.....	8
1.7.2 Misuse.....	8
2. Technical Information.....	8
2.1 Operating Principles.....	8
2.2 Safety Devices.....	8
3. Supply.....	8
4. Transport and handling.....	8
5. Installation.....	9
5.1 Installation of External Installation Versions.....	9
5.2 Installation of Semi-Recessed Installation Versions	9
6. Condensate runoff pipe.....	9
7. Electrical Connection.....	9
7.1 Two-Phase Models.....	9
7.2 Three-phase models.....	9
7.3 Alarm Pins.....	9
7.4 Sequencing (optional).....	9
7.5 Modbus (optional).....	9
8. First Start-Up and Regulation.....	9
8.1 Electronic Thermostat.....	9
8.2 Electronic Board.....	9
9. Maintenance.....	10
10. Removal and Dismantling.....	10
11. Troubleshooting.....	10
12. Pictograms.....	23-24-25
13. Technical data.....	26-27
14. Performances.....	28-29
15. Dimensions.....	30-31
16. Spare parts.....	32-33-34-35
17. Guarantee.....	36-37
18. Assistance service.....	38
19. Notes.....	39

1 General Information

⚠ WARNING

Read the following instructions carefully before installing and using the product.

1.1 Overview

The product is manufactured by TEXA INDUSTRIES S.r.l. in compliance with applicable EC directives; more specifically, it complies with the requirements of the Machinery Directive 2006/42/EC and applicable harmonised and safety regulations pursuant to the same directive.

1.2 Purpose of the Manual

This manual contains all information for safe installation, use and maintenance of the product.

1.3 Symbols Contained in this Manual

⚠ WARNING

Indicates that failure to comply with these instructions can lead to serious or even fatal personal injury.

⚠ CAUTION

Indicates that failure to comply with these instructions can lead to less serious injury or damage to the product.

📄 NOTICE

Indicates information which is important for use of the machine.

1.4 Retention of Documents

This manual, in combination with the rest of the digital/hardcopy documentation, represents an integral part of the product.

Ensure this documentation is available for consultation by all persons who use the product and personnel authorised to carry out maintenance operations.

📄 NOTICE

Store the documentation with care in a clean, dry location until the product has been disposed of.

1.5. Updates

TEXA INDUSTRIES S.r.l. reserves the right to update its products and the corresponding manuals based on technical progress without prior notice. Please note that at the time of sale, this manual and the corresponding product may not be considered inadequate only because they are not subject to the above-mentioned progress.

1.6. Technical Features

The technical features and CE marking are given on the data plate attached to the machine.

The product is supplied with safety instruction manual, wiring diagram, specific test report and CE declaration of conformity.

1.7. Cooling Unit Application

The NXT series cooling units described in this manual are designed and built to cool the air inside electrical switchboards in order to protect components sensitive to thermal shock. They also provide IP55 protection level against the infiltration of contaminating and aggressive/corrosive substances.

1.7.1 Intended Use

Use the NXT cooling unit:

- For cooling electrical switchboards
- Within the temperature limits and with the supply voltages specified on the rating plate (F.04, pos.

5) applied to the cooling unit, and in table F.13 of this manual

- Away from any sources of heat or hot air
- In an environment with adequate air exchange
- On switchboards with IP54 rating or higher. If these requirements are not respected, excessive condensation build-up may occur. As a consequence, cable entry points or any other openings in the enclosure should be well sealed.
- So that the compressor always remains upright.

1.7.2 Misuse

⚠ WARNING

Incorrect or careless use may cause irreparable damage to the cooling unit and may lead to hazardous situations.

Do not use the NXT cooling unit:

- Under any condition except those described in section 1.7.1
- In explosion-risk atmospheres, or those with aggressive chemicals or excessive concentrations of dust, solid contaminants, chemicals or oil suspended in the air
- Exposed to the elements, strong radiated heat sources or strong magnetic fields
- With the doors of the electrical switchboard open, or installed on enclosures without a minimum IP54 rating, due to excessive condensate formation
- With the temperature set below the dew point of the ambient air
- With the condensate line closed or blocked off, or in any case in which the condensate is not allowed to run off freely
- Without the front panel
- With the cooling unit intake and outlet air flows obstructed by walls or objects that are too close To this end, check the minimum distances as regards the external air flow (figure F.02), and make sure there are no obstructions caused by the switchboard components as regards the internal air flow.
- In a position other than that for which it was designed, installed neither on moving, oscillating nor vibrating parts

📄 NOTICE

The product warranty shall automatically be rendered void if it is not used under the conditions laid out above, and in the event of any tampering by the customer. TEXA INDUSTRIES S.r.l. shall bear no liability in the event of faults or malfunctions due to failure to comply with the instructions provided.

📄 NOTICE

To ensure correct operation, the specified scheduled maintenance operations (see section 9) must be performed regularly.

2. Technical Information

2.1 Operating Principles

The cooling unit for electrical switchboard enclosures works on the basis of a refrigeration circuit consisting of four main components: compressor, evaporator, condenser and expansion device (figure F.12). The refrigeration circuit is sealed and contains R134a refrigerant, which is chlorine free and ozone friendly. The unit is divided into two hermetically separated sections where the ambient air and enclosure air do not come into contact with one another and are treated separately. The compressor (CP) compresses the refrigerant, taking it to a high pressure and high temperature. The compressor then pushes the refrigerant through a heat-

exchanger coil, called the condenser (C), where it is cooled by ambient air, thus passing from the gas to the liquid state. In the liquid state it then passes through the expansion valve (EXP), vaporising at the outlet as it is now at a much lower pressure. It is then received by the heat exchanger coil, called the evaporator (E), by means of which it absorbs heat from the enclosure air and passes from a liquid state to gas. The enclosure is cooled down in this manner. The gaseous refrigerant is then drawn back into the compressor and this cycle is repeated.

2.2 Safety Devices

⚠ WARNING

DO NOT disable the safety devices; any such modification, in addition to causing a hazard, would immediately invalidate the product warranty.

The refrigeration circuit is fitted with an EN 12263 compliant high-pressure safety switch P (figure F.12) set to the maximum working pressure of the cooling unit. If this threshold is exceeded, the pressure switch cuts out the compressor, before restoring it automatically. The fans and compressor have an (internal or external) thermal cut-out switch that stops them in the case of overheating.

3. Supply

Inside the packaging you will find:

- 1 Cooling unit
- 1 Safety instruction manual
- 1 CE conformity certificate
- 1 Test certificate
- 1 A4 drilling template
- 1 Wiring diagram
- 1 Installation kit containing (F.04):
 - Flanged nuts (1)
 - Flat washers (2)
 - Grub screws (3)
- 2 Connectors, one for the power supply (F.04) and one for the signals (F.05)
- 1 Self-adhesive sealing strip (F.04, 4)
- 1 Hose barb for the condensate discharge (F.10, 1)
- Transport/handling eyebolts from NXT12 to NXT60 (F.03)

4. Transport and handling

⚠ WARNING

Ensure the following operations are performed by qualified and authorised personnel, equipped with appropriate PPE.

⚠ WARNING

Do not exceed the maximum manual handling weight for loads specified by law. Use lifting equipment as required.

⚠ CAUTION

Dispose of the packaging materials in an environmentally friendly manner.

On receipt, check that the packaging does not show signs of damage from transport. Once the packaging has been removed, make sure the product shows no signs of dents or damage and that no oil is leaking from the circuit.

During transport and storage, the cooling unit must be kept in a vertical position, as indicated on the packaging (figure F.01) and must not be exposed to temperatures above 70°C or below -20°C. To lift the cooling unit in a safe manner use the supplied eyebolts (included from NXT12); these should be fitted into the threaded inserts located on the top of the cooling unit (figure F.03).

NOTICE

Immediately contact TEXA INDUSTRIES S.r.l. in writing in the event of any damage or other discrepancies.

5. Installation**WARNING**

Disconnect power before starting any work inside the switchboard.

WARNING

Installation of the machine must be performed only by authorised and qualified personnel using appropriate PPE.

CAUTION

Debur holes and slots to prevent cuts, above all during the installation phase.

Install the cooling unit with the enclosure air intake hole in the highest possible point.

Ensure the fixing elements and couplings will not foul the equipment inside the enclosure itself.

If the cooling unit is to be installed on the door of an electrical switchboard, make sure the door can take the weight.

The unit must be installed in a vertical position. Maximum permitted deviation from the vertical is 2°.

5.1 Installation of External Installation Versions

The cooling unit must be installed on the outside of the electrical switchboard. Drill the holes and make the necessary cuts in the enclosure (figure F.04) using the drilling template supplied with the unit. Fit the sealing strip on the cooling unit on the side connected to the enclosure and follow the assembly diagram (figure F.04).

5.2 Installation of Semi-Recessed Installation Versions

Thanks to its modular configuration, depending on requirements the cooling unit can be installed on the exterior of the electrical switchboard (figure F.05) or semi-recessed (figure F.06) without the need for further accessories. Depending on the installation option, drill the holes and make the necessary cuts in the switchboard using the drilling template supplied with the unit. Fit the sealing strip on the cooling unit on the side connected to the enclosure. Follow the installation diagram given, depending on the required installation type.

6. Condensate runoff pipe

The condensate which, depending on the ambient temperature and humidity conditions, forms on the cooling unit which cools the enclosure air, is not a malfunction but a normal phenomenon of the cooling unit. In models **NXT04-NXT06-NXT08**, this condensate is taken outside through a hose at the bottom of the cooling unit. It is possible to screw on the hose barb supplied with the machine (figure F.10) on which an 8 mm ID hose can be fitted to carry the condensate to another position, so that the discharge can be made at a point where it does not represent a slipping hazard to personnel. In this case, make sure the condensate flows without any hindrance. Avoid horizontal lengths of more than 0.5 metres, uphill sections and the accidental formation of traps (figure F.07). The end of the condensate runoff pipe must always be free and never underwater. The end of the condensate runoff pipe must therefore not be placed inside a condensate collection container (figure F.08). Models **NXT10** to **NXT60** are fitted with a condensate evaporation device which operates via the hot (outlet) tube of the compressor

(figure F.13). These models nevertheless have an emergency condensate outlet which can be carried outside as described above. If the cooling unit is used with the doors of the enclosure open, excessive quantities of condensate will form and this is an unauthorised condition of use (figure F.09). We suggest using a position switch on the door connected to the cooling unit's digital input to stop the unit if the door is opened. (See section 7.3)

7. Electrical Connection**WARNING**

The electrical connection and any work on the system or on electrical components must be performed solely by specialised and authorised personnel in compliance with electrical code and any other applicable regulations.

WARNING

Isolate the power to the enclosure during the connection phase.

WARNING

Ensure the machine is correctly earthed.

CAUTION

Make sure the supply voltage is compatible with the voltage on the cooling unit's rating plate.

CAUTION

The power supply must be protected upline of the machine using appropriate time-delay fuses (type T) or circuit breakers with K-curve, per the indications given in table F.13.

Connect the supply cable in accordance with figure F.14.

7.1 Two-Phase Models

The two-phase models can operate with two different supply voltages: 460V 2~50-60Hz and 400V 2~50-60Hz. If the available power supply is 460V 2~50-60Hz, connect terminals L1(0) and L3(460) on the terminal board (figure F.14). If, on the other hand, the available supply voltage is 400V 2~50-60Hz, connect terminals L1(0) and L2(400) on the same terminal board.

The UL-listed models are fitted with fuses on the 460V 2~50-60Hz supply line located in the corresponding fuse holders in the rear part of the cooling unit (figure F.16).

7.2 Three-phase models

The three-phase UL-listed models with 460V 3~60 Hz power supply can also be powered with 400V 3~ 50 Hz voltage by opening the rear panel and modifying the connection of the cables on the quick-release connector (figure F.19). On the contrary, the models with only CE marking are factory set for 400V 3~ 50 Hz and can be powered with 460V 3~ 60 Hz voltage by modifying the connection with the same procedure described previously.

The UL-listed models are fitted with fuses on the 460V 3~ 60Hz supply line located in the corresponding fuse holders in the rear part of the cooling unit (figure F.16).

7.3 Alarm Pins

(figure F.15)

The input/output signals from the electronic control unit are managed via the alarm pins:

- Alarm signals from the electronic control unit can be taken from positions 1-2-3; in the event of an alarm, the digital output relay will change state
- A digital input for voltage free contacts is available on terminals 4-5

The cooling unit's electronic control unit is programmed to generate an alarm when the digital input is open. When the digital input is not being used, it is therefore necessary to bridge it by connecting terminals 4 and 5 together with a cable.

7.4 Sequencing (optional)

(figure F.17)

It is possible to connect two cooling units together in sequence via the red 4-pole connector on the rear of the machine; the cable is not supplied as standard.

See the control unit manual to set the necessary parameters.

7.5 Modbus (optional)

(figure F.18)

It is possible to make a modbus connection via the 4-pole connector on the rear of the machine; the cable is not supplied as standard.

See the control unit manual to set the necessary parameters.

8. First Start-Up and Regulation**CAUTION**

If, prior to installation, the cooling unit was left in an incorrect position (figure F.01), wait at least 8 hours before switching it on. Otherwise, 30 minutes is more than enough time for the oil to return to the compressor, after which the cooling unit can be powered up.

Once voltage is applied, the enclosure air intake fan will operate intermittently, making the temperature inside the enclosure even. If this temperature exceeds 2K above the set point, both the compressor and external air fan will turn on, causing the cooling cycle to start. This then stops when the inside temperature reaches the set point. The thermostat is factory-set to 35°C. The setpoint can be set between 20°C and 45°C.

NOTICE

To save energy and minimise the production of condensate, we recommend not setting the setpoint below 30 °C.

8.1 Electronic Thermostat

The **NXT04** model is fitted with a TX050 electronic thermostat. See the specific manual C17000199 for the functions of this thermostat and how to program it.

8.2 Electronic Board

All other models in the **NXT** range are equipped with an electronic board and a display on which the operator can modify the machine parameters. See the specific manual C17000905 for the functions of this thermostat and how to program it.

NOTICE

TEXA INDUSTRIES S.r.l. shall be in no way held liable for any alterations the customer may make to the default parameters if they have not received authorisation to do so.

9. Maintenance

⚠ WARNING
Before commencing any operation, shut off the power supply to the machine.

⚠ WARNING
Scheduled and extraordinary machine maintenance must be performed only by authorised and qualified personnel using appropriate PPE.

⚠ WARNING
Wait for the surfaces of the internal components to come to ambient temperature.

⚠ CAUTION
DO NOT use acidic or flammable detergents to clean the product.

The cooling unit is the low maintenance type, so no filter change is required. The only maintenance required is for the internal components, which should be checked regularly, as indicated in the following table, and cleaned with compressed air at a maximum pressure of 4 bar (figure F.11).

Job	Frequency
Check the external air heat exchanger and clean if necessary.	Every 3 months
Check effectiveness of the condensate discharge.	Every 3 months
Check the fans for any overheating or excessive vibrations.	Every 6 months

ℹ NOTICE
Increase the frequency of these operations if the machine is operated in very dusty and dirty environments.

10 Removal and Dismantling

⚠ WARNING
Before commencing any operation, shut off the power supply to the machine.

⚠ WARNING
Removal and dismantling of the machine must be performed only by authorised and qualified personnel using appropriate PPE.

The cooling unit contains R134a refrigerant and small quantities of lubricating oil. These are polluting substances and must not be dumped. Have personnel certified per Regulation (EU) 517/2014 recover the refrigerant so that it can be reused, regenerated or destroyed.

12. Troubleshooting

Malfunction	Conditions	Causes	Remedy	
It fails to cool	The internal fan works, the external fan and compressor do not work.	The temperature inside the enclosure is lower than what is set on the adjustment thermostat.	This is not a malfunction of the cooling unit. To verify functioning when testing, lower the thermostat setting until the compressor and external fan start working and then reset the thermostat.	
		The adjustment (or antifreeze) thermostat has failed	Change the adjustment (or antifreeze) thermostat	
	No component works	No electricity getting to the unit.	This is not a malfunction of the cooling unit.	<ul style="list-style-type: none"> Make sure the power cable has been connected well to the terminals. Check that the cubicle doors and switches are closed
			Call a refrigeration expert or the Manufacturer's Technical Assistance Service	
	Compressor, external and internal fan work	Cooling unit empty of fluid	Call a refrigeration expert or the Manufacturer's Technical Assistance Service	
		Compressor mechanical failure	Call a refrigeration expert or the Manufacturer's Technical Assistance Service	
	Compressor and external fan work, internal fan does not work	Internal fan capacitor failed	Change the internal fan's capacitor	
		Internal fan failed	Change the internal fan	
	External and internal fan work, compressor does not work	Compressor's amperometric protector failed (external to the compressor, where present)	Relay or PTC for compressor starting failed	Change the relay or PTC for compressor starting
			Capacitor for compressor starting failed (where present)	Change the capacitor for compressor starting
Compressor motor electrical failure			Call a refrigeration expert or the Manufacturer's Technical Assistance Service	
High pressure safety switch failed			Call a refrigeration expert or the Manufacturer's Technical Assistance Service	
It is not cooling enough	External and internal fans work, compressor works all the time	Cooling unit under sized for the heat dissipated inside the enclosure	Change the cooling unit with another of greater capacity	
		Antifreeze thermostat triggered (where present)	<ul style="list-style-type: none"> Clean the evaporator coil See if there are any obstacles inside the enclosure to hinder the flow of recycling air 	
		Insufficient gas in the cooling unit	Call a refrigeration expert or the Manufacturer's Technical Assistance Service	
	External and internal fans work, compressor works irregularly	Thermostat set point incorrect	Check thermostat setpoint	
		High pressure safety switch triggered:	<ul style="list-style-type: none"> Ambient temperature over the maximum working limit Heat exchanger coil (condenser) either dirty or clogged 	<ul style="list-style-type: none"> Ventilate the premises where the enclosure is installed to keep ambient temperature lower. Clean the exchanger with compressed air and detergent
			Thermal protector inside the compressor triggered:	<ul style="list-style-type: none"> Ambient temperature over the maximum working limit Heat exchanger coil (condenser) either dirty or clogged
		Too much condensate forming		Enclosure door open
Enclosure door closed	Enclosure protection level is below IP54		This is not a malfunction of the cooling unit. Seal enclosure openings, e.g. for passage and upward path of wires	
			The enclosure/cooling unit connecting seal has been fitted incorrectly	Check seal and remedy

12. Pictograms

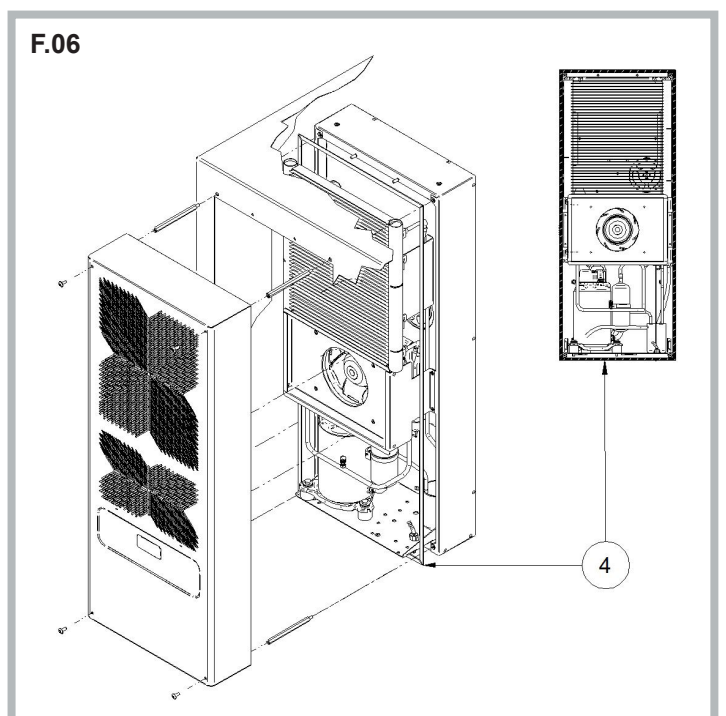
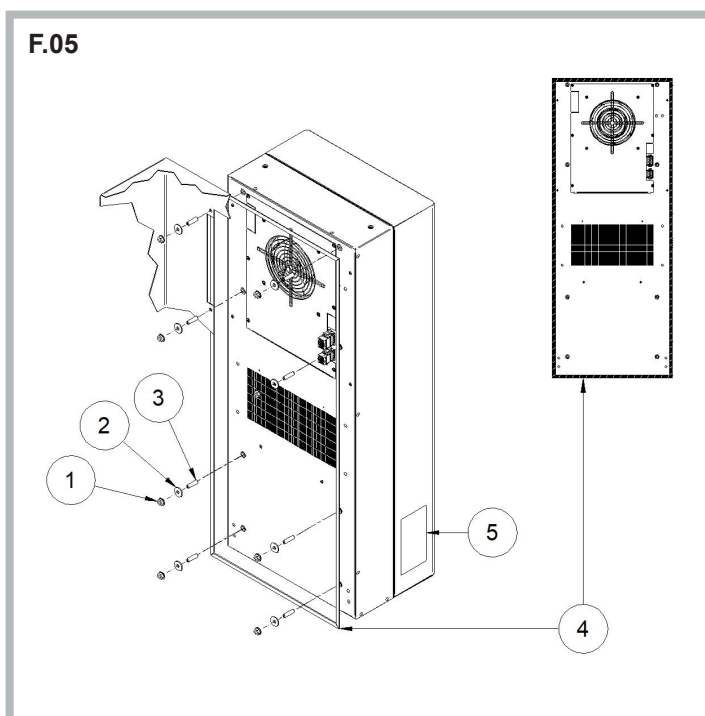
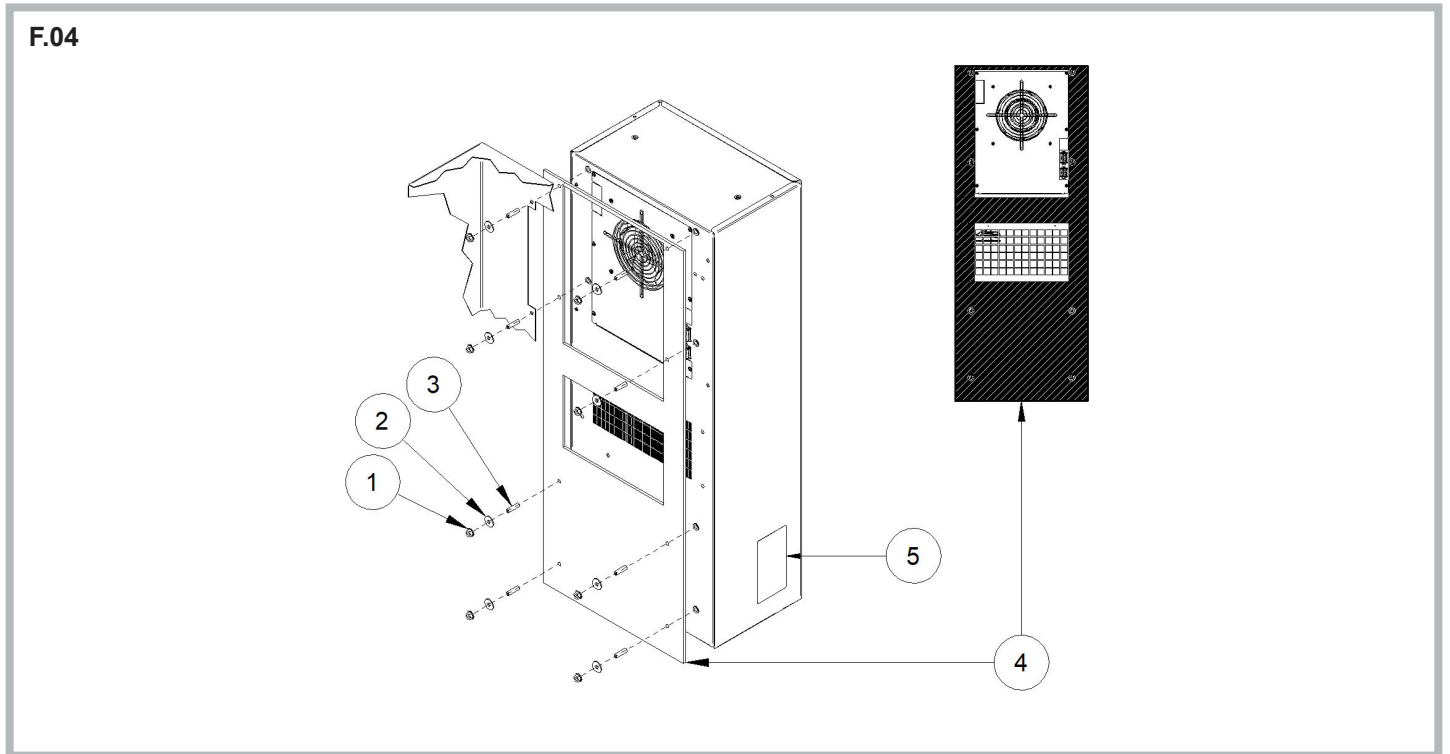
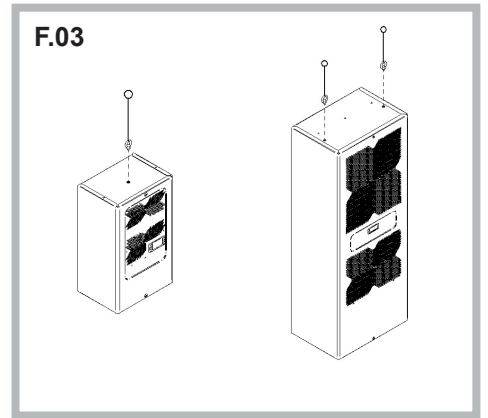
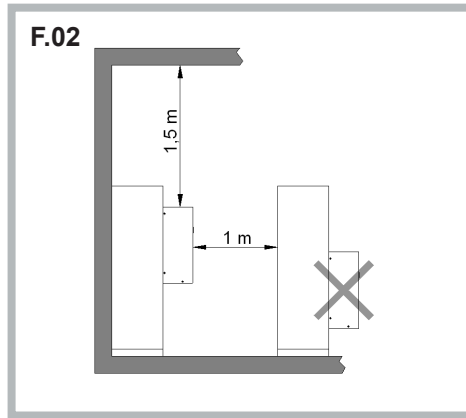
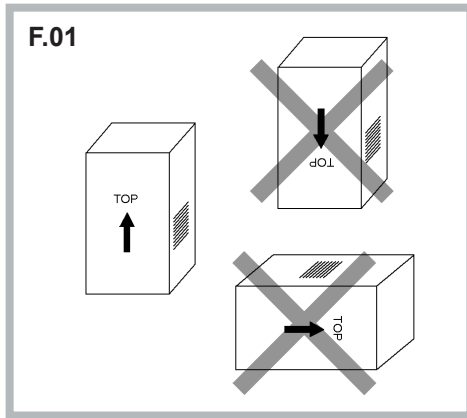

12. Pictograms

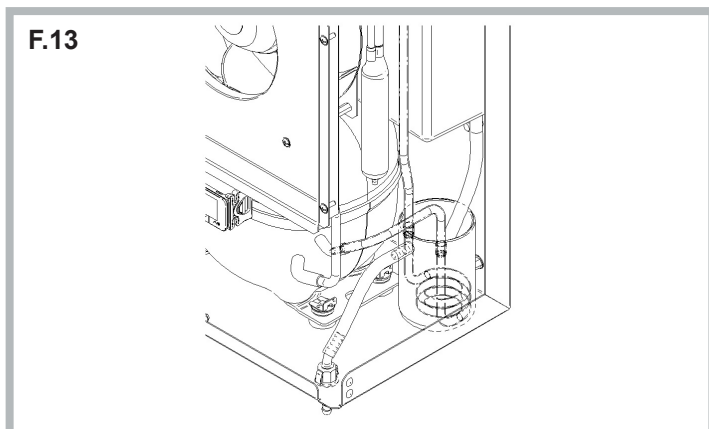
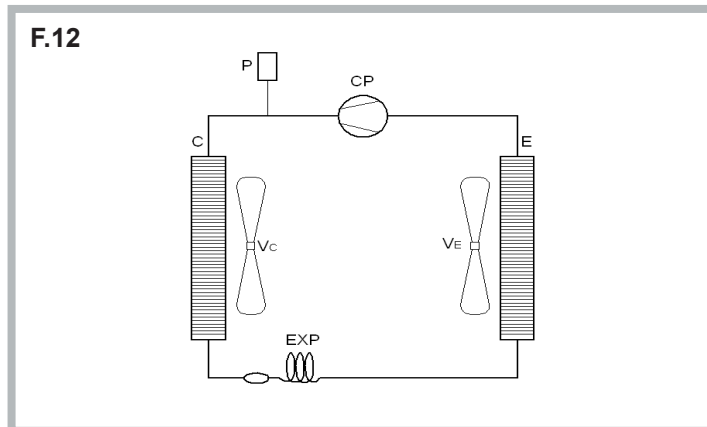
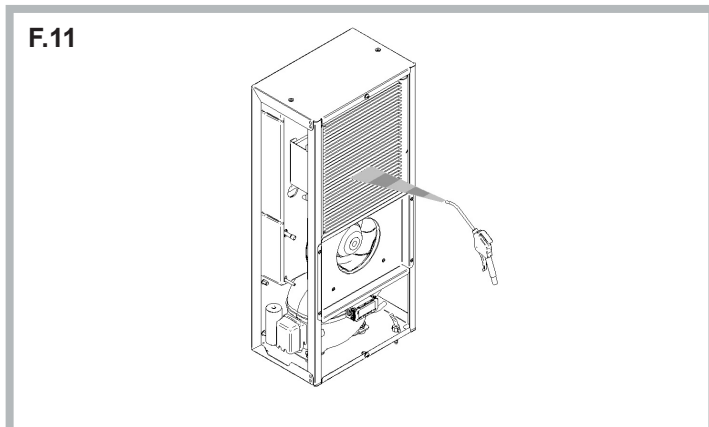
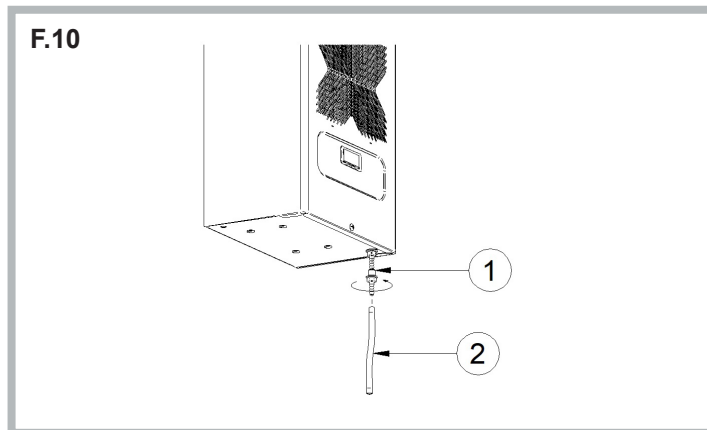
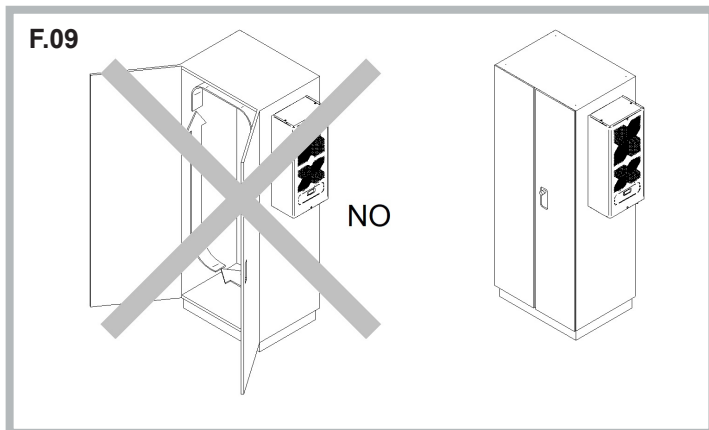
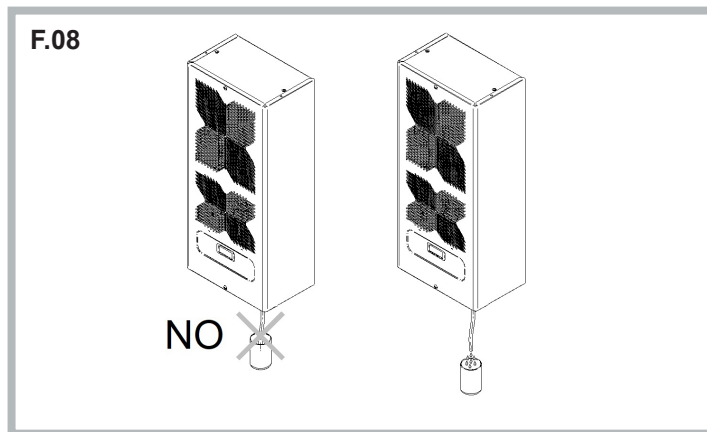
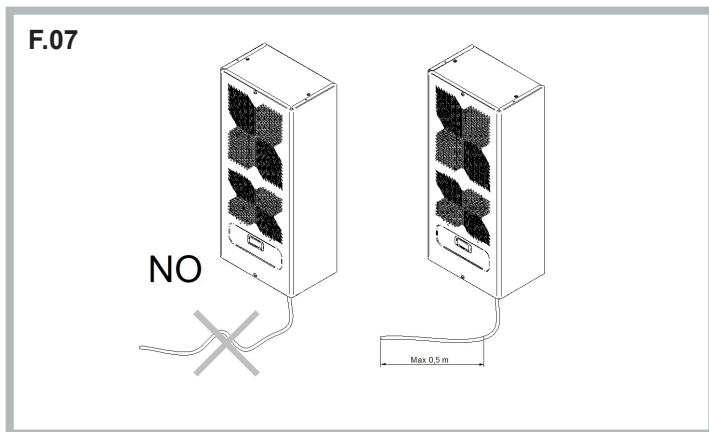

12. Pictograms

F.14

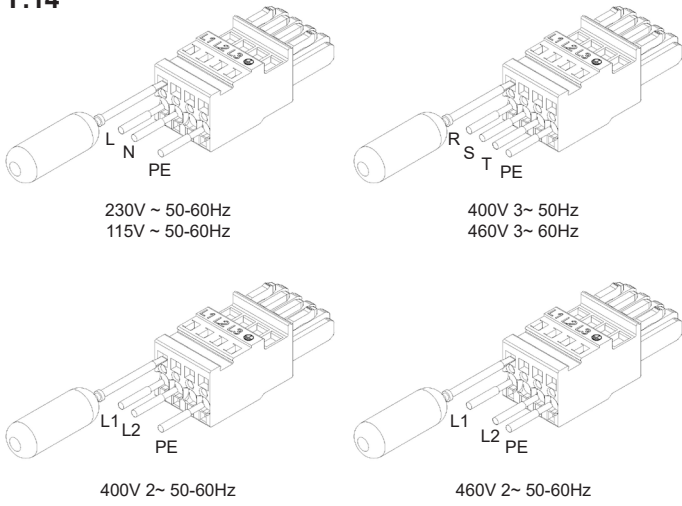

F.15

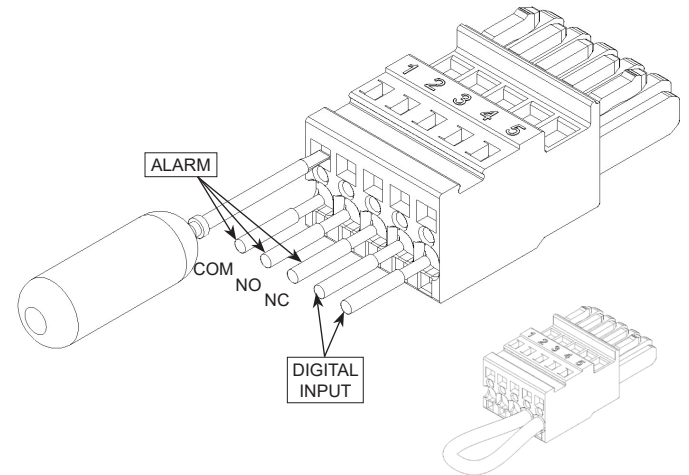

F.16

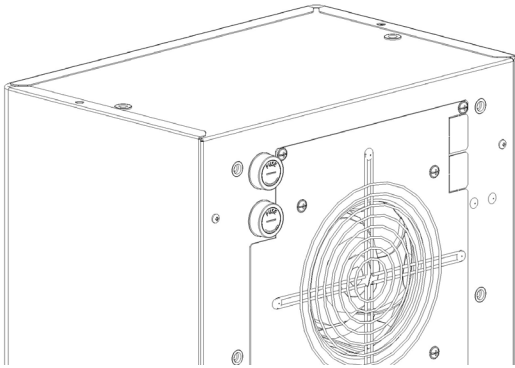

F.17

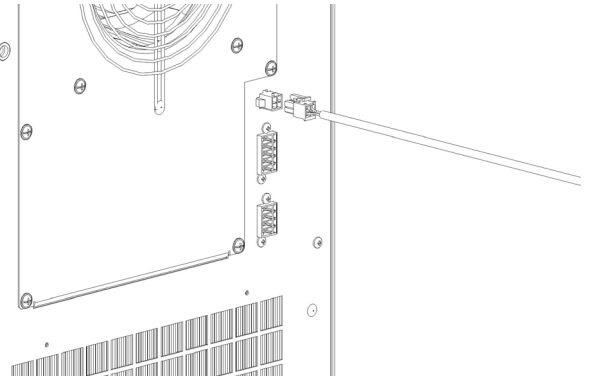

F.18

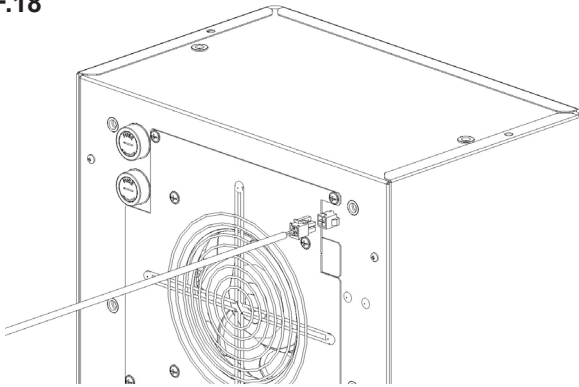

F.19

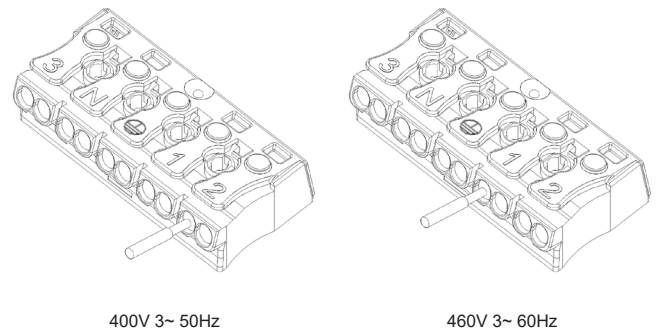

14. Performances

F.21

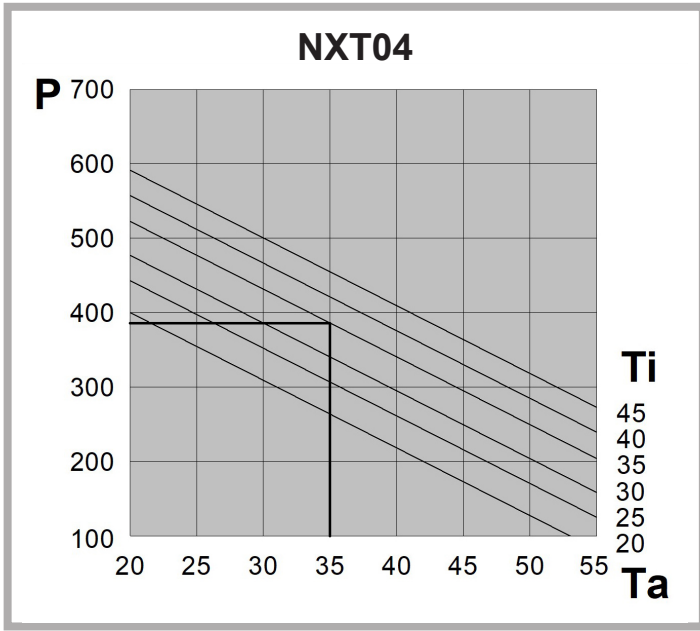

15. Dimensions F.22

NXT04

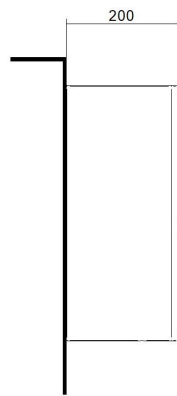
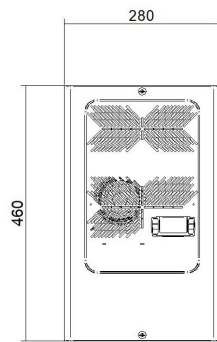

External Mounting
Montaggio Esterno
Außenmontage
Montage externe
Montaje externo

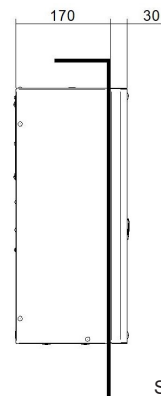

Semi-recessed mounting
Montaggio semi-incasso
Halbeinbaumontage
Montage semi-encasté
Montaje semi-empotrado

16. Spare parts / Ricambi / Ersatzteile / Pièces détachées / Piezas de repuesto

	ENG	
1	Front structure	
2	Condenser	
3	Evaporator	
4	Compressor	
5	Condenser fan	
6	Evaporator fan	
7	Electric Control	
8	Display	
9	Electronic Board	
10	Autotransformer	
11	Assembly accessory kit	

16. Spare parts / Ricambi / Ersatzteile / Pièces détachées / Piezas de repuesto
F.23

NXT04

